

Sensorex load cells  
Isobox  
reset amplifier  
Isomatic control panel  
ep converter transducer



 **Renova**  
WE NEVER LOSE CONTROL

control system

# sensorex

load cells

The Renova's load cells have been studied to be used, together with rolls, for the tension of a web (paper, plastic film, tissue, etc.).

## Guide for the selection of the load cell

To select the load cell suitable to your needs it is necessary to determine the cell model depending on the technical characteristics of the machine, the load that it will support and the size of the hole.

### model selection

The selection of the load cell type has to be done according to the specifications of your machine. For this reason Renova offers flange load cells SX-CF series and flange load cells with clearance hole SX-CH series as well.

serie **SX-CF**

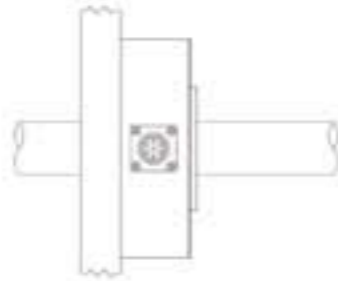

serie **SX-CH**

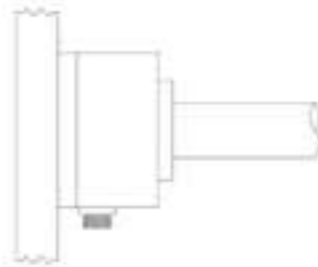

### cell's load selection

After having selected the load cell model basing on the characteristics of your machine you need to select the load that the cell should support according to the web tension and the roll weight

T= tension  
P= roll weight  
F= resultant on load cells

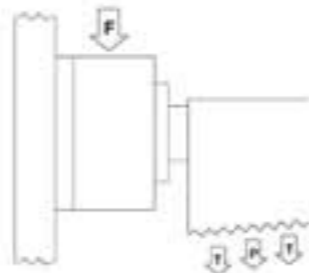

### cell's hole selection

After having selected the cell's model and load you need to select the cell's hole diameter according to the pilot of the roll.

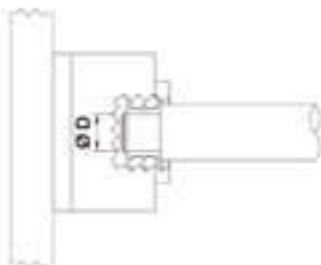

## Cell's load calculation

To determine the cell's load it is necessary to calculate the total of the forces that gravitate on it, that is the sum of the components of the laminate and the roll weight.

### legend

- = resultant direction
- a = winding angle
- F = resultant on load cell (daN)
- T = max tension (daN)
- P = roller weight (daN)

### Resultant horizontal direction

A configuration with horizontal resultant isn't affected by the roll weight. It offers a better precision when web tension is low.

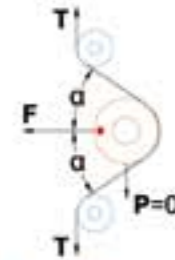

$$F = 2T\cos\alpha$$

### Resultant downward direction

A configuration with downward resultant enhances the load on the cell due to the component of the roll weight. This component has to be canceled in the setting of the control panel.

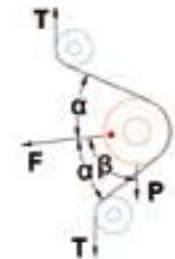

$$F = 2T\cos\alpha + P\cos\beta$$

### Resultant upward direction

A configuration with upward resultant reduces the load on the cell due to the component of the roll weight. This component has to be canceled in the setting of the control panel.



$$F = 2T\cos\alpha - P\cos\beta$$

\*The F force has then to be divided for the number of cells per roller. Ex: with 2 cells the referred force for the dimensioning of the cell will be F/2

load cells

flange load cells

## sensorex SX-CF series

Available in SX-CF.85  
and SX-CF.130 versions

### Distinctive features and applications

The Renova's load cells SX-CF.85 and SX-CF.130 have been studied to be used, together with rolls, for the tension of a web (paper, plastic film, tissue, etc.). Usually, a load cell is applied at each side of the sensor roll, in order to give in output a signal proportional to the web wrapped on the roll.

The flange load cells are available in different models with load from 15 to 500 kg. The Renova's load cells are tested and correlated with a certificate that attests the perfect conformity to the technical data required.

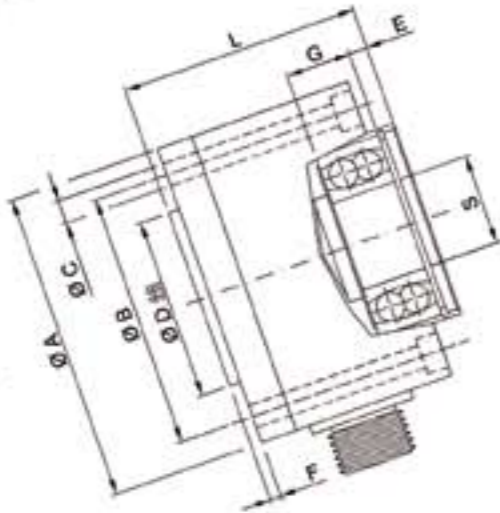
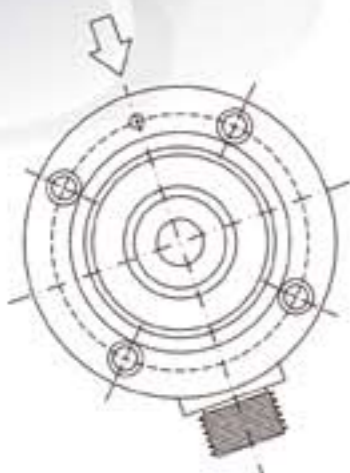

Type	Range (daN)
SX-CF.85.15	0÷15
SX-CF.85.25	0÷25
SX-CF.85.50	0÷50
SX-CF.85.100	0÷100
SX-CF.130.100	0÷100
SX-CF.130.250	0÷250
SX-CF.130.500	0÷500

	A	B	C	D	E	F	Ø pivot S	L
SX-CF.85	85	70	6,5	50	5	3	15 - 17-20-25	63
SX-CF.130	130	108	10,5	75	5	5	25-30-35	85
Ø pivot S	width G		Ball bearing 22002RS					
15	14		15 x 35 x 14					
17	16		17 x 40 x 16					
20	18		20 x 47 x 18					
25	18		25 x 52 x 18					
30	20		30 x 62 x 20					
35	23		35 x 72 x 23					

## SX-CF series with integrated amplifier

Load cells series SX-CF are also available  
with integrated amplifier

### Distinctive technical features

- output signal 4 ÷ 20mA
- input signal 12 VDC
- to be used to obtain a greater stability of signals or for cable lengths > 5 meters.



### Mounting load cells SX-CF series

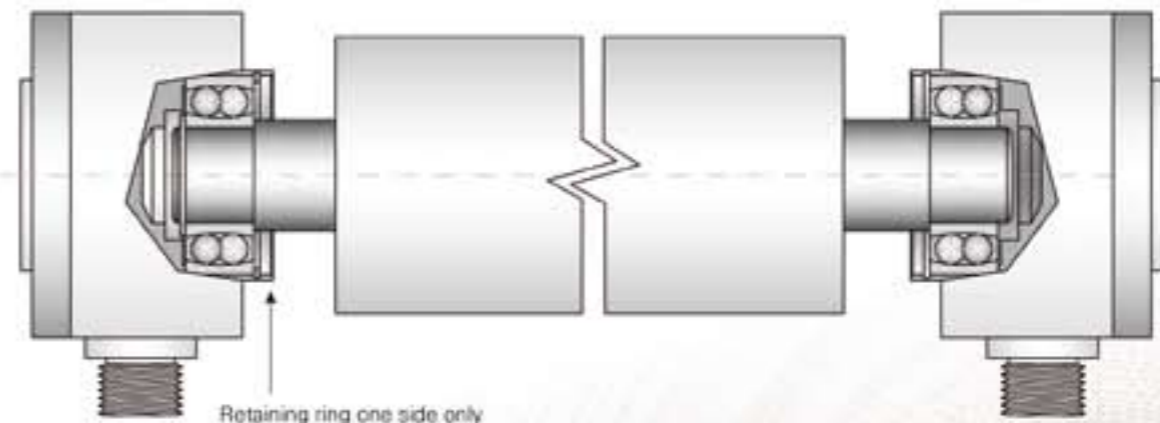

6 poles socket for shielded cable

code for order

**SX-CF 0. 0. 0. 0.**

- Ø load cells
- range
- Ø shaft
- A: with integrated amplifier

mounting

flange load cells with clearance hole

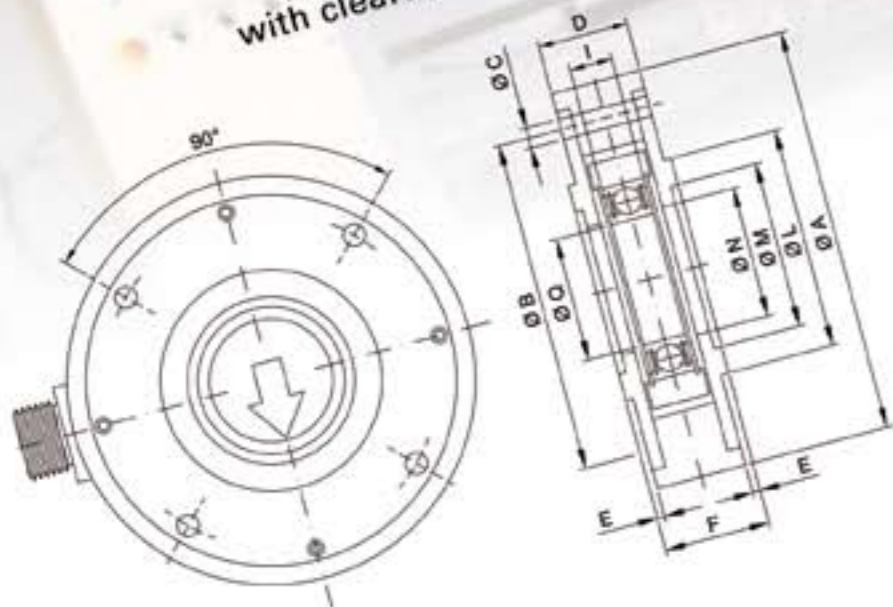

## sensorex SX-CH series

### Distinctive features and applications

The flange load cells with clearance hole have been conceived as a valid alternative to the SX-CF.85 and SX-CF.130 series load cells, where the application of sensor rolls with through shaft is required.

Their compact shape and the possibility to reach high load ranges, make these cells a versatile answer to several applications.

## SX-CH series with integrated amplifier

Load cells series SX-C are available also in the version with integrated amplifier

### Distinctive features and applications

output signal  $4 \pm 20\text{mA}$

input signal 12 VDC

to be used to obtain a greater stability of signals or for cable lengths > 5 meters.

Type	Range daN	A	B	C	D	E	F	I	L <sub>g6</sub>	N	Q
SX-CH 100-25-12	0÷25	100	70	4x6,5	30,5	3	36,5	14	50	16	12
SX-CH 105-50-17	0÷50	105	75	4x6,5	30,5	3	36,5	16	60	22	17
SX-CH 105-100-17	0÷100	105	75	4x6,5	30,5	3	36,5	16	60	22	17
SX-CH 125-100-25	0÷100	125	95	4x6,5	39,5	4	47,5	18	70	31	25
SX-CH 125-150-25	0÷150	125	95	4x6,5	39,5	4	47,5	18	70	31	25
SX-CH 175-300-35	0÷300	175	135	4x6,5	57	4	65	23	100	44	35
SX-CH 265-3000-65	0÷3000	285	220	4x10,5	72	4	80	23	160	88	80

### cells mounting on shoulder external side

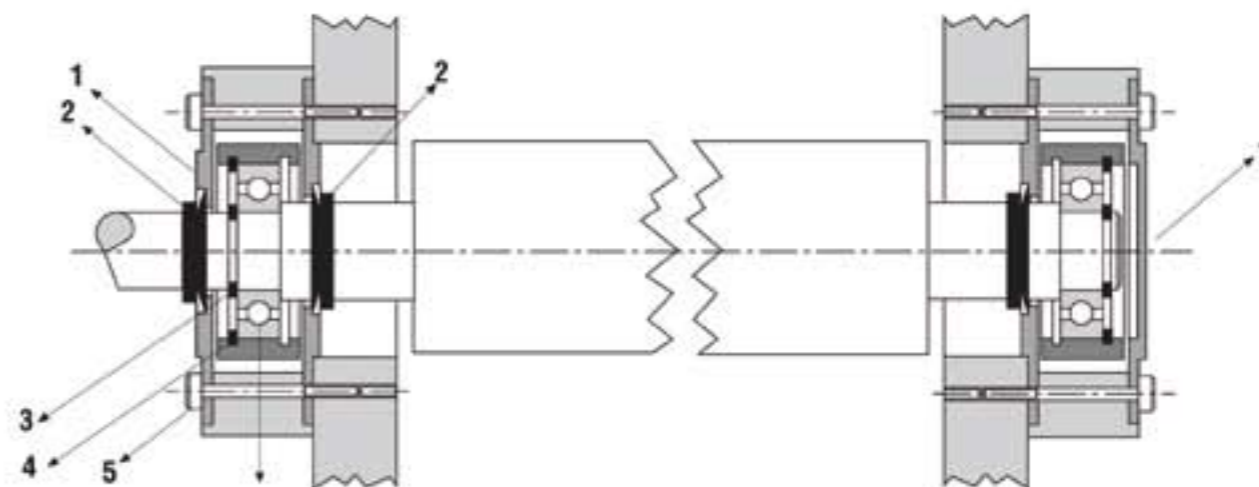

### cells mounting on shoulder internal side

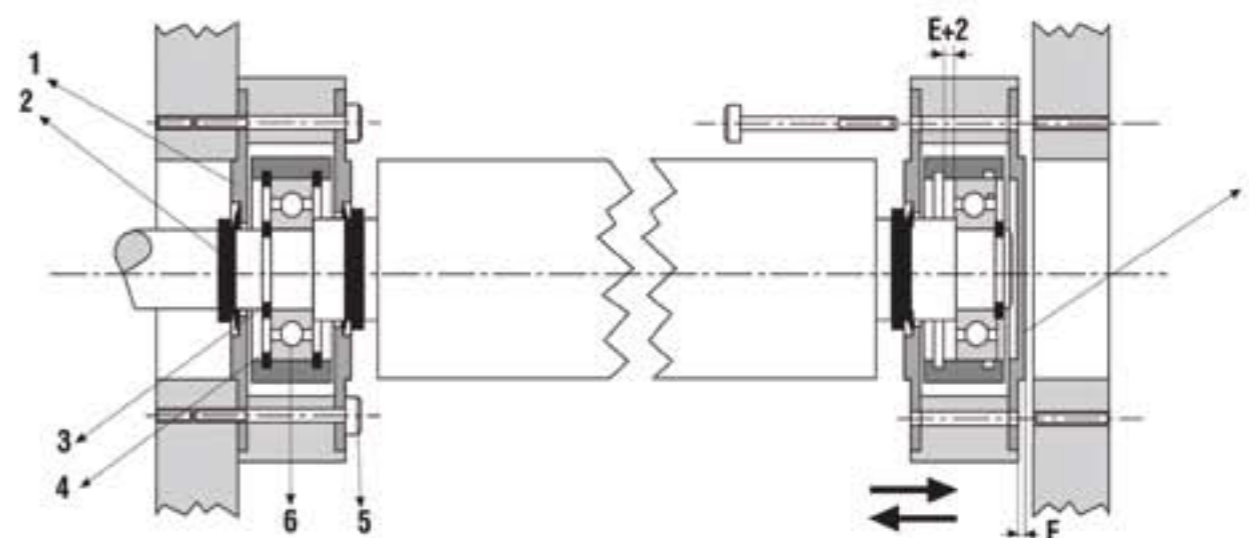

- 1 - through cover
- 2 - V-RING seal
- 3 - SEEGER ring for shaft
- 4 - SEEGER ring for hole

- 5 - fixing screw
- 6 - Bearing
- 7 - Blind cover
- E+2 = deviation dimension requested for fixing

code for order **SX-CH 0.0.0.**

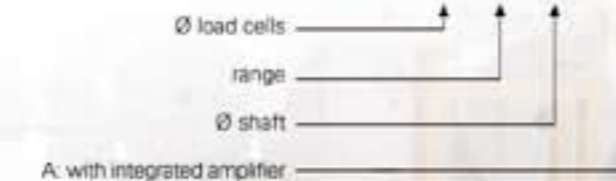

mounting

technical data

### sensorex load cells technical data

Accuracy class	0,5%
Load F max	300 kg
Sensitivity (output)	1,6 mV/V
Output for load cell with integrated amplifier	4 ± 20 mA
Recommended excitation	5 ± 10V
Alimentation for amplifier PCB	12 V DC
Maximum excitation	15V
Input resistance	368 Ohm
Output resistance	351 Ohm
Insulation resistance	> 5 G Ohm
Non linearity	< 0,05 %
Repeatability	< ± 0,03
Working temperature	-20°C ++ 70°C
Protection class	IP 60
Material	steel
Temperature effect on rated output (5°)	< 0,0015%
Accepted overload	120% F
Maximum safe load	150% F

colours code

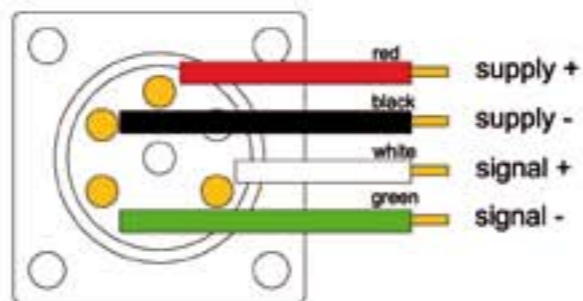

# reset

## Measuring amplifier load cells for web tension

Digital measuring amplifier for strain gauges bridge, including a 24 bit acquisition circuit with programmable gain, 3 analog outputs towards a supervision unit and a digital input the zeroing of remote outputs.



### Technical data:

- Amplifier with microprocessor at 24 bit
- Assembling on DIN guide step 23 mm
- Four numbered display
- RS 485 optional expansion card
- Profibus DPv1 optional expansion card

### Electronical signals:

- Input: 24 Vdc
- Analog outputs: 4-20mA/10 Vdc
- Output digital signals: 24 Vdc

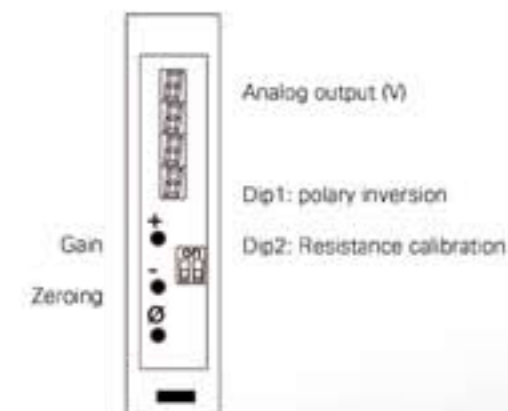
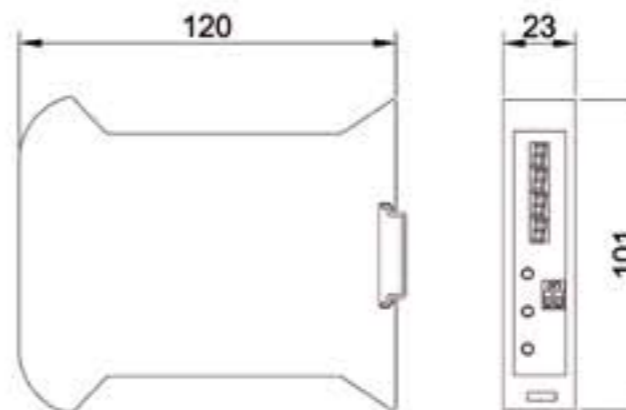

### code for order

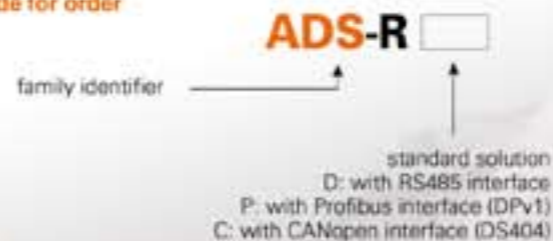

digital measuring amplifier

# isomatic

control panel

## Control panel

Completely manage the process by configuring necessary functions on the display. Additional functions can be customized on your request.



- Advanced regulation capabilities:**
- Complete management of PID functions
  - Open or closed loop regulation
  - Compensation of reels inertia in different stages
  - Programmable acceleration and deceleration time instead of the set point
  - Decreasing tension regulation (taper)
  - Management program of rolls change no-stop

## technical data

supply	24 VDC
capacity	5W max (no load)
cells analogue input	0-10 mV (type 2mV/V)
analogue input	0-10 V / -20 mA
analogue output (2X)	± 10V
capacity output	0-24V / 10A
digital input (4X)	24V (PNP)
output input (4X)	24V (PNP, max 100 mA)
degree of protection	IP 20 (case), IP54 (frontal panel)

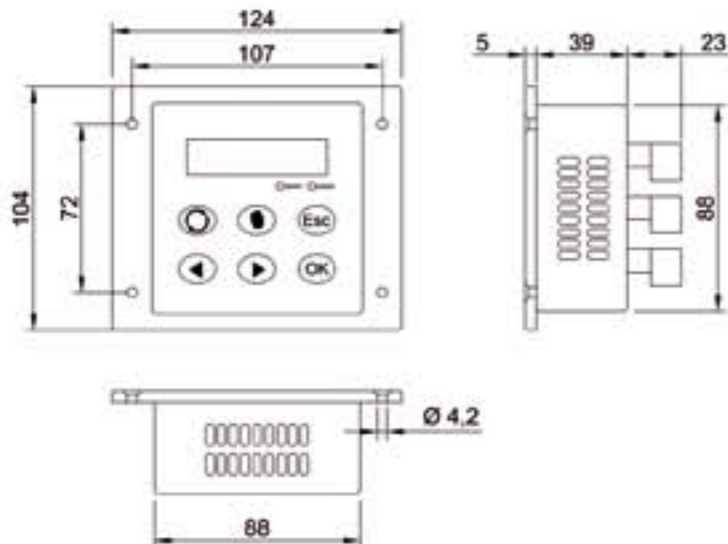

When mounting load cells, it is possible to connect the instrument directly to the load cell bridge (full or half bridge).

# ep converter

## Transducer

Electropneumatic converter that converts an electrical signal into compressed air with a pressure directly proportional to the signal provided.



It ensures accuracy in tension with power supply of 24 VDC and signal from 0 to 10 V.

## technical data

medium	oil free, dry air filtered to 5 µm	
output pressure	0-6 BAR (0-90 psi)	
supply pressure	minimum 1.5 BAR (22 psi) above maximum output pressure	
electrical connection	0-10 V	
	4-20 mA	
supply	24 VDC ± 10%	
flow capacity	forward: <200 l/min (7 scim)	relief: <180l/min (8 scim)
air consumption	~6 BAR (90 psi) = <3 nl/min	
degree of protection	IP 30	
electromagnetic compatibility	Compliant with EC requirements	
materials	diaphragm: nitrile	base: zinc casting spacer: aluminum

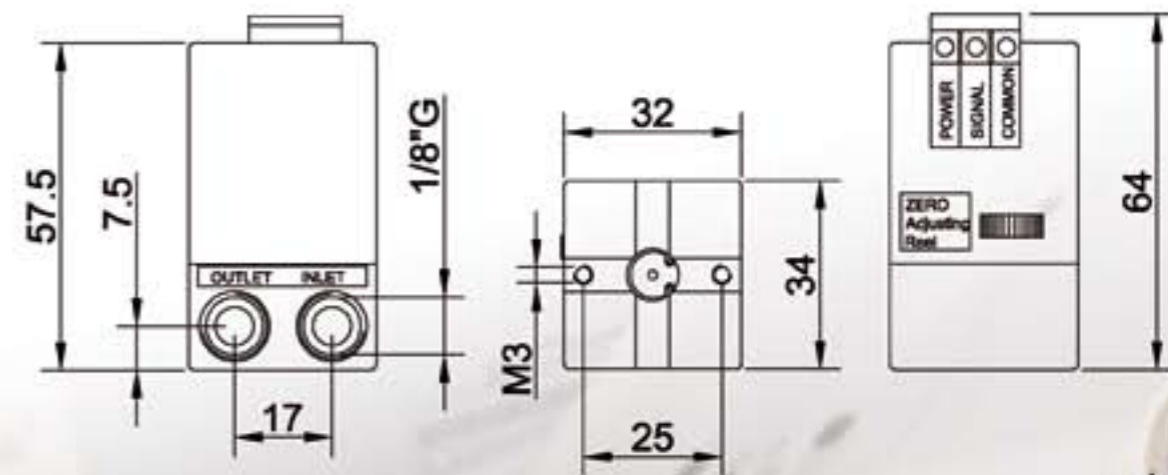

transducer

complete tension control system

**isobox**

**Complete tension control system**

Isobox is an integrated system for the automatic tension regulation of the Isomatic control panel and Ep converter transducer.

The Isobox system is easy to use and ready to mount. With Sensorex load cells, it is ideal for unwinders equipped with the Turborex pneumatic multidisc brakes



Input supply	220-240 V 50-60 Hz 3.2 A
Input pressure	Max 8 bar
Input load cells signal	2 X 6-pin connector EN 60529
Output supply	24V 6.25A
Output pressure	0-6 bar
Drives	Left and Right brake Manual and Automatic mode
Security	On/Off electrical button
Regulation	Automatic regulation by panel and manometer Manual regulation by manual regulator and manometer
Operating temperature	0-50°

**(1) Regulation with load cells**

The control panel ISOMATIC receives the signal of the web tension from load cells and regulates:

- Pneumatic brake with a control signal 0 ÷ 10 VDC sent to an electro-pneumatic transducer that converts it to 0 to 6 bar
- Magnetic powder brake with a power signal 0 ÷ 24 VDC / 10A max directly to the brake

**Functions**

- Input for load cells
- Signal amplifier
- Data visualization on display
- P.I.D Logic
- Voltage output
- Max/min voltage alarm
- Adjustment parameters settable (PID , acceleration , deceleration etc)

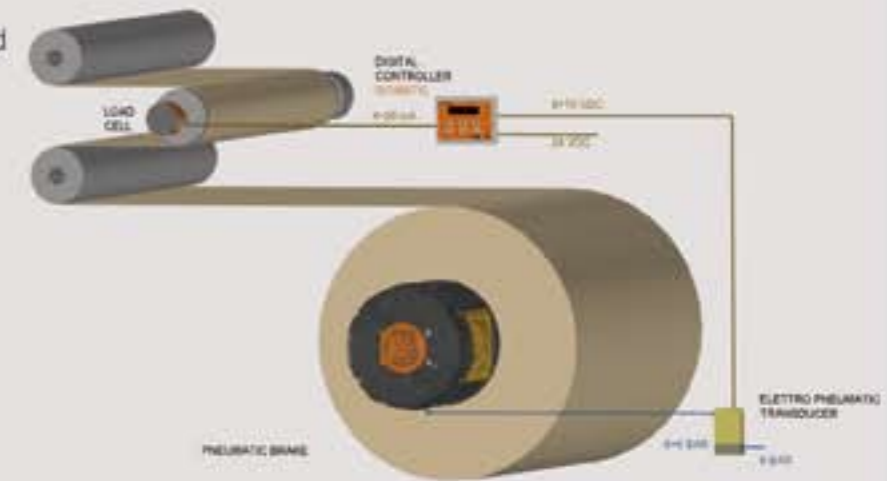

**(2) Regulation with dancer roll**

The control panel ISOMATIC receives the signal of the web tension from the displacement of the roll dancer and regulates:

- Pneumatic brake with a control signal 0 ÷ 10 VDC sent to an electro-pneumatic transducer that converts it to 0 to 6 bar
- Magnetic powder brake with a power signal 0 ÷ 24 VDC / 10A max directly to the brake

**Functions**

- Dancer potentiometer input
- Data visualization on display
- P.I.D Logic
- Voltage output
- Max/min voltage alarm
- Adjustment parameters settable (PID , acceleration , deceleration etc)

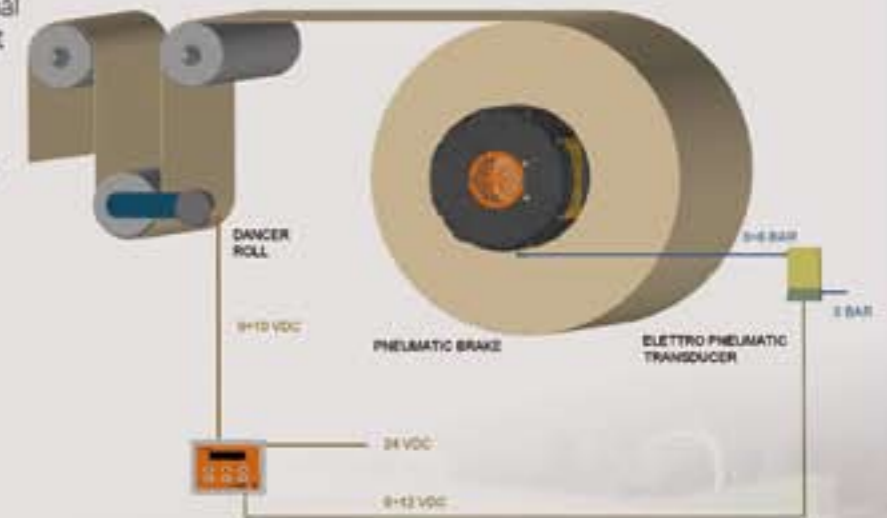

regulations



### (3) Regulation with ultrasonic sonar

The control panel ISOMATIC receives the signal of the variation of the coil diameter and regulates:

- Pneumatic brake with a control signal 0 ÷ 10 VDC sent to an electro-pneumatic transducer that converts it to 0 to 6 bar

- Magnetic powder brake with a power signal 0 ÷ 24 VDC / 10A max directly to the brake

#### Functions

- Input for sensor 0 ÷ 10 VDC / 4 ÷ 20mA
- Data visualization on display
- P.I.D Logic
- Voltage output
- Max/min voltage alarm
- Adjustment parameters settable (PID , acceleration , deceleration etc)

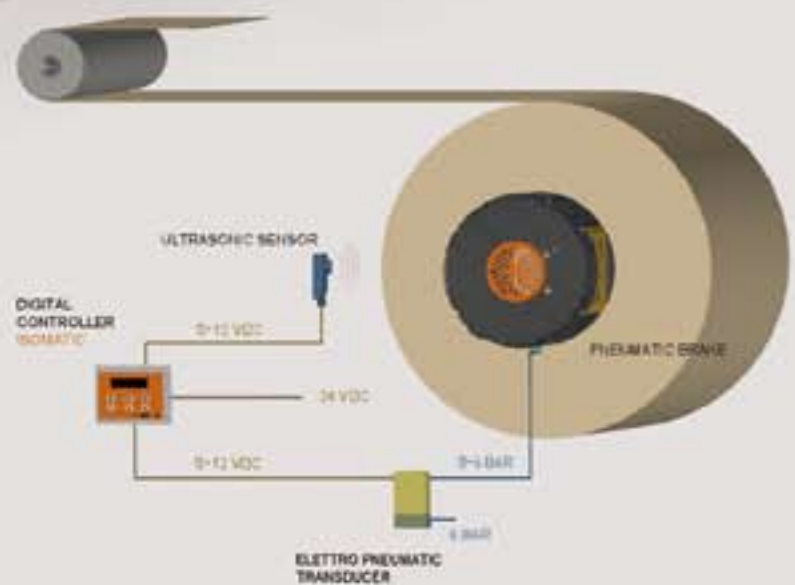

## product range

Renova offers a wide product range covering the needs of manufactures and end users in the paper, corrugated cardboard, aluminum, adhesive tape, printing, textile, and plastic industries.

## turborex

A multi-disc brake with double fan ventilation. This patented system reduces internal temperatures and virtually eliminates maintenance costs and brake pollution. The Turborex brake is available in TX110, TX120, TX170, TX180 and TX240 models and carries a torque range from 0-400 daNm with a power dissipation of up to 12 kW.



## combirex

A mono-disc, multi-caliper, air-cooled brake. It reaches a maximum torque of 96 daNm and a power dissipation of 3kW. This CX model uses a 250 mm disc and is available with up to 6 caliepers.



## powderex

Magnetic powder brakes with a torque range from 1-12 daNm. Radiator cooling or axial fan cooling.



## mechanical chucks

Chucks for automatically centering a roll of any load and diameter. Available with or without the mechanical core ejector for core diameters of 3" to 12". Also available in a dual-diameter step chuck.



## moviroll

Moviroll is ideal for the handling of corrugated rolls, paper and tissue paper rolls, wood/steel rolls for cable, etc.

All it needs is a compressed air connection to start working safely and effortlessly.





Renova Srl is an Italian manufacturer and supplier of web tension control systems with four decades of application know-how.

With its wide product range, Renova extends its business to many application fields (paper, corrugated board, aluminum, tapes, printing & flexo, slitter, cutting, machinery, tire) to the complete satisfaction of the most important machine builders and end users.

Renova's brakes, chucks, load cells, rollpushers, and web tension control panel are all 100% designed and made in Italy. This Renova choice is representative of a direct control of the entire production chain to ensure the highest product quality.



 **Renova**  
WE NEVER LOSE CONTROL

Renova srl  
via Pompeo Mariani 16  
20128 Milano - Italy  
phone: +39 02 27007394  
fax: +39 02 25708635

web site: [www.renova-srl.it](http://www.renova-srl.it)  
e-mail: [info@renova-srl.it](mailto:info@renova-srl.it)

CATSYENA4V1114