

// Highest precision for
guiding your web:
BST eltromat Web Guiding.

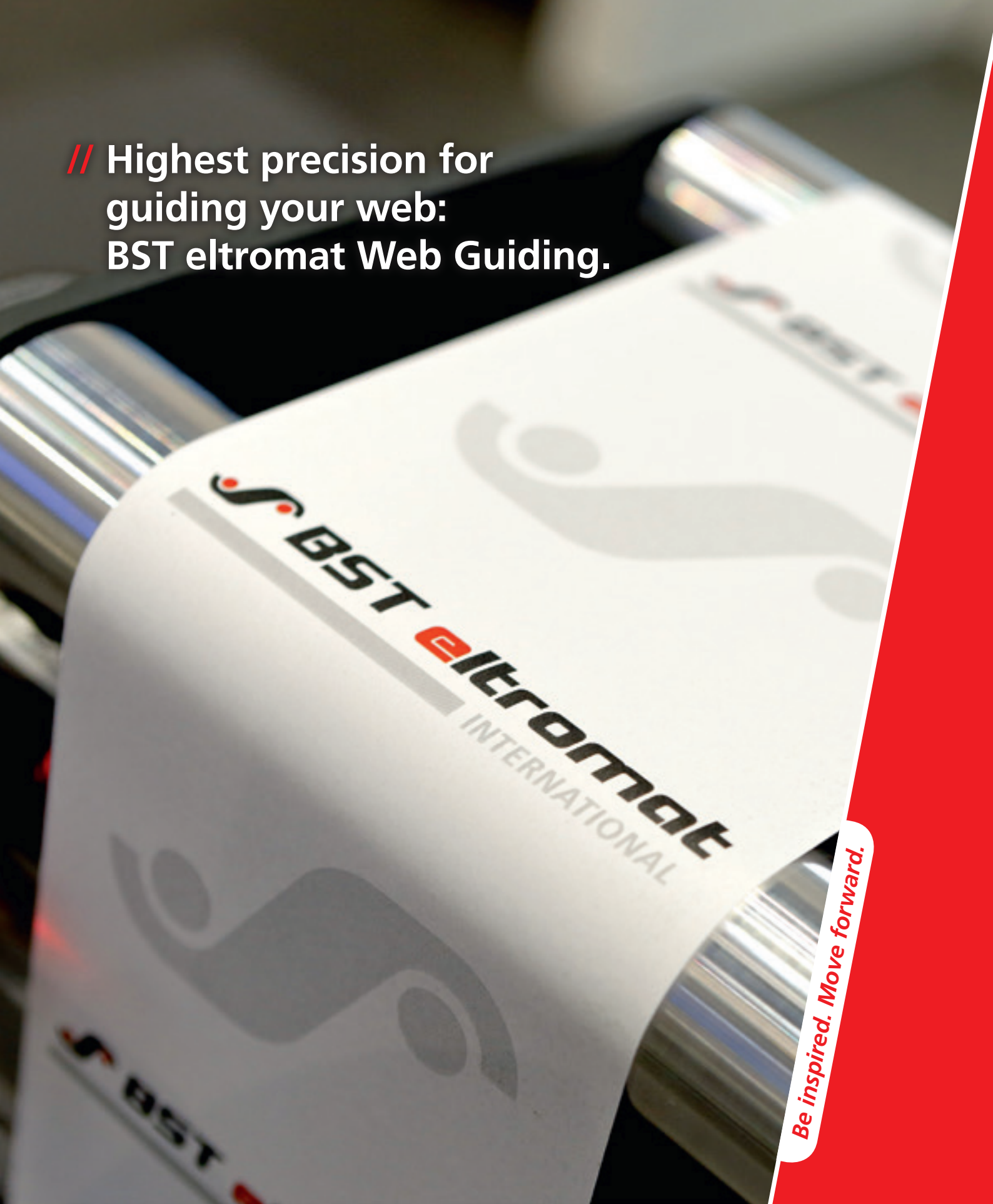

Be inspired. Move forward.

EFFICIENT WEB GUIDING – RELIABLY GUIDED.

Growing production speeds and increasing quality demands: Modern production machines for processing web-shaped materials are e.g. used in the printing industry at speeds which were exceptional only a few years ago. At the same time, providers may only be successful in competition with reliably accurate results.

The challenge: It is very important to use the machine speeds to the full extent and to simultaneously ensure that everything runs smoothly and in a controlled manner, from unwinding the material, guiding it through the production process until rewinding it.

Continuous and accurate web guiding: BST eltromat systems control the web guiding in different production processes, e. g. in the paper, foil and rubber industry as well as in conveying and transport plants. When in use, the BST eltromat web guiding ensures that the processed material strictly remains in its intended position. BST eltromat web guiding systems can be used for a wide range of substances and effectively minimise spoilage and downtimes.



BST ELTROMAT IN USE

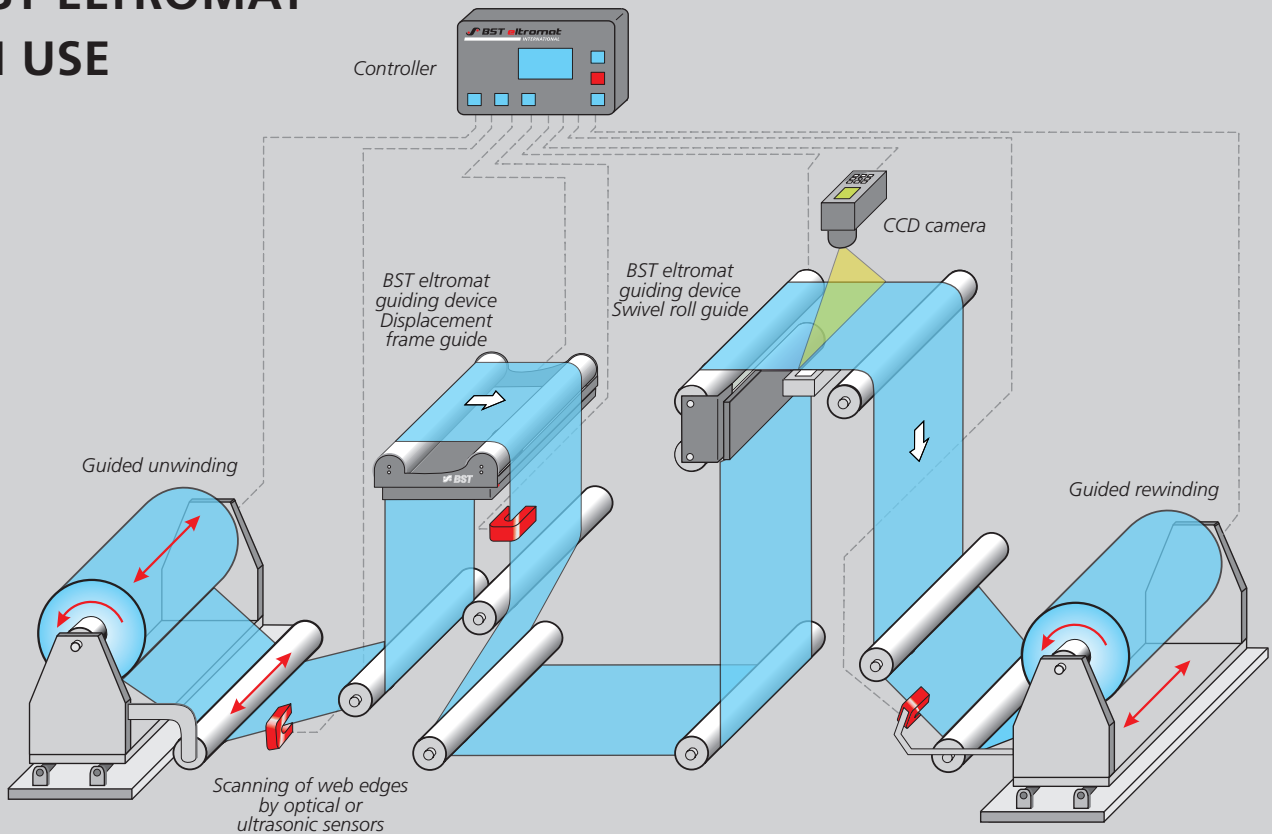

Examples:



Controller ekr 500 digital

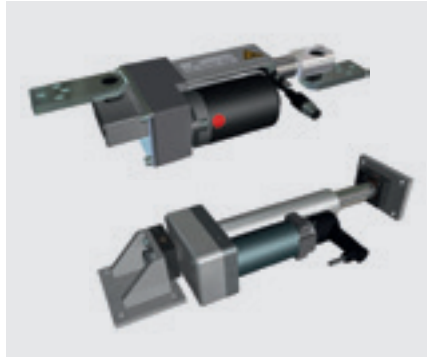

Actuators

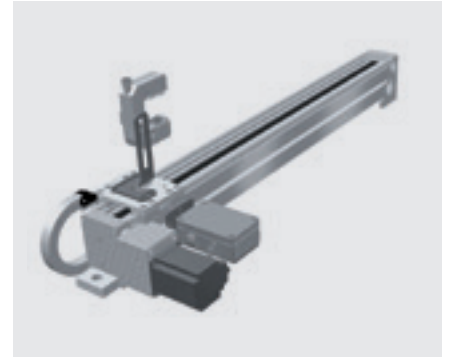

Sensor positioning device FVGPro with sensor

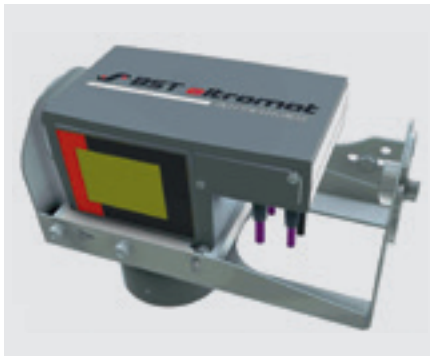

Camera CCD CAM 100



Additional remote control



Line and contrast sensor CLS Pro 600

PERFECTLY UNDER CONTROL: THE BST ELTROMAT CYCLE FOR PERFECT PRECISION.

Aligned to your production: In their scope and automation level, BST eltromat web guiding systems exactly comply with the requirements of your production process when it comes to scope and automation level.

Controlling systems for each processing degree

How the path of your production web is best controlled depends on the processing level of the web. Unprocessed webs may only be adjusted by means of the web edge or web centre-line, since the web itself does not have any further contrast features. Finished webs, on the other hand, offer more options for sensor-based position detection thanks to, for example, printed lines and freely selectable contrasts.

Web guiding types

Regarding the web edge guiding, guiding is realised depending on the left or right web edge by means of an edge sensor. During web centre-line guiding, two edge sensors detect the position of the web centre-line as the basis for the position setting. Contrast controlling procedures are oriented on continuous or broken printed lines or a contrast edge.

Precision due to experience

As the leading manufacturer of quality-assuring systems for the web processing industries, BST eltromat International has already installed more than 100,000 systems in over 100 countries worldwide.

At a glance: The BST eltromat loop

All BST eltromat web guiding systems are based on a single closed loop:

 The **current position** of the material web is the starting point...

 ...and is detected as the **actual position** by one or more **sensors** and is then transferred to the controller...

 ... The **controller** compares these actual values with the defined **target value**. If a deviation is detected, the controller sends a corresponding **correction signal** to the...

 ...**actuator** which accurately corrects the position of the material web with almost no delay.

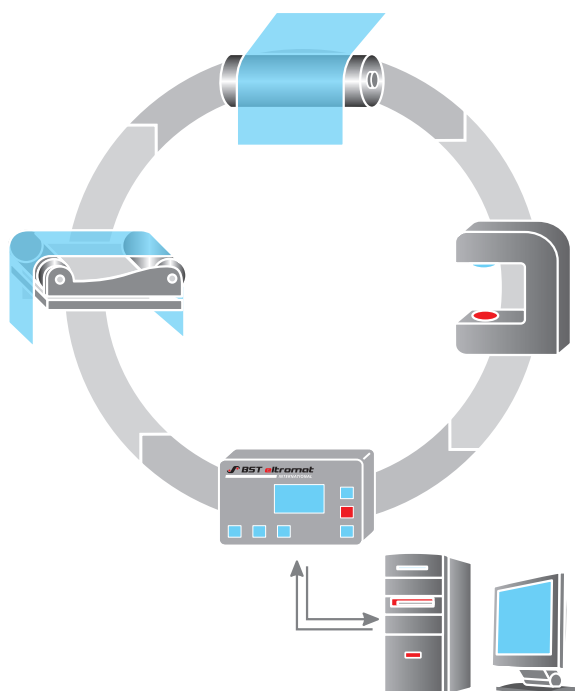

PRECISE CORRECTION WITH EACH INSTALLATION POSITION.

In the web processing industry, the material is normally supplied on rolls, unwound for further processing, guided through the production process and finally rewound at the end of the machine. Misalignments frequently occur during these procedures, therefore web guiding systems secure the process at all critical spots.

But what happens when the measured web position deviates from the target position?

If the measured actual position of the web deviates from its target position, the guiding device – moved by the actuator – performs corrections until the target position is reached.

This can be realised by means of different types of guiding devices, e. g. displacement frame guides, swivel frame guides, turning bars and guided rewinding/unwinding.



At a glance:

Guiding devices may be used for your application in a flexible manner – depending on:

- the web width
- the web tension
- the material to be processed and its admissible wear
- the space available in the machine

The guiding devices are available in different design sizes and types for almost all web widths and application fields. Additionally, there is also a number of roller designs and coatings available for various material types.

BST ELTROMAT GUIDING DEVICES: YOUR CHOICE FOR FIRST-CLASS CORRECTION PROCESSES.

Displacement Frame guide (DF)

Structure

Fixed lower frame and rotating upper frame with a pivot located on the infeed of the web.

Functionality

In the case of web path errors, the upper frame moves around its pivot and passes the material web on to a defined position on the next idler roller.

Scope of application

- lowest material wear in short control range
- Especially suited for delicate materials

Advantages

- Variable installation positions
- Low actuating power required

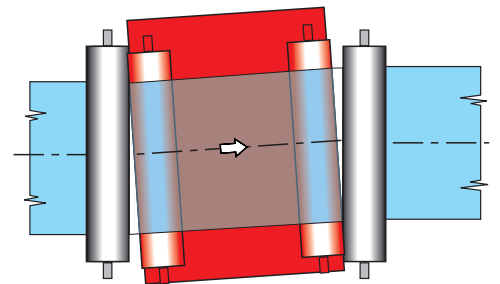
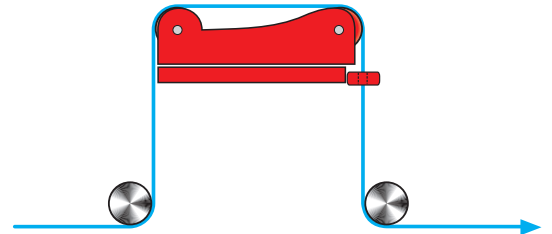

Functional principle of the displacement frame guide

EXAMPLES OF INSTALLATION POSITIONS

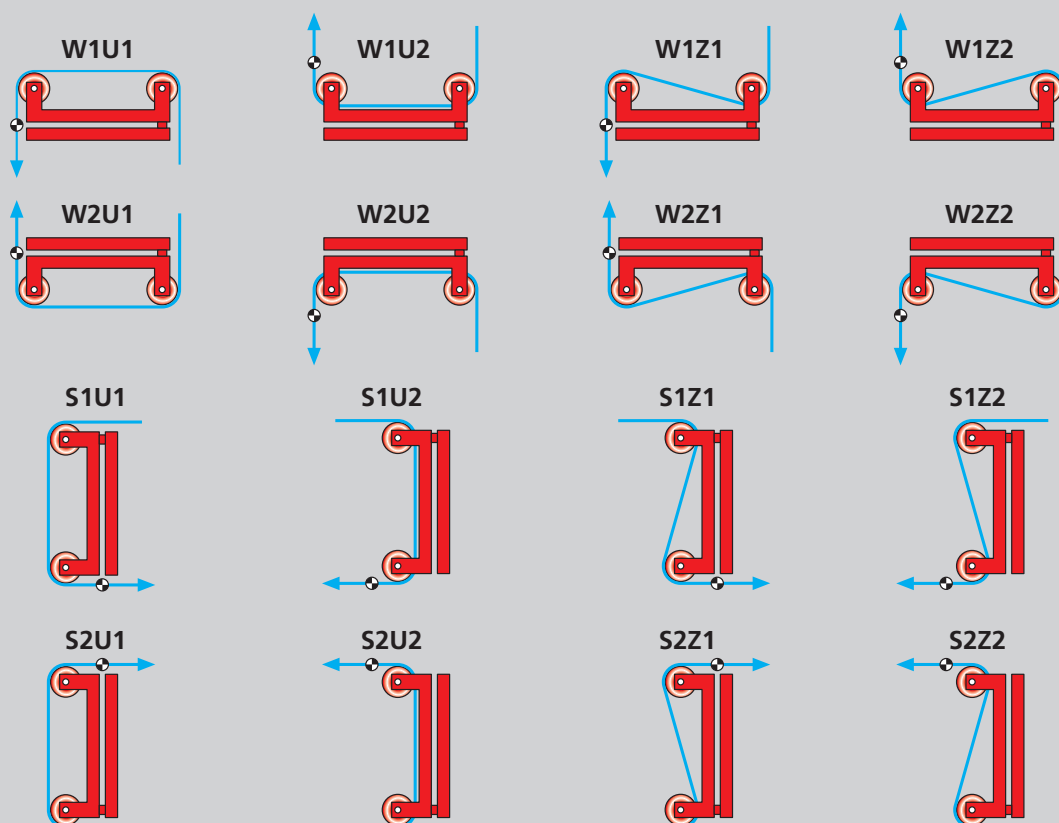

BST ELTROMAT GUIDING DEVICES

Swivel Frame guide (SF)

Structure

Fixed lower frame and movable upper frame with one or two guiding rollers.

Functionality

The upper frame moves around an infeed-sided fictive pivot outside of the guiding device. When a web path error occurs, the guiding device swivels laterally and guides the outfeed web to a defined position on the next idler roller. The correction is already performed on the infeed level.

Scope of application

- In adequate long infeed and exfeed spans
- If the required web thread does not allow the use of a rotating frame guide

Advantage

- Can also be used in limited installation space

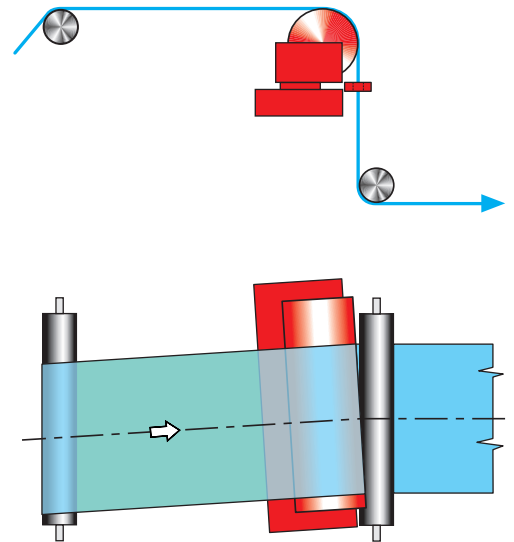

Functional principle of the swivel frame guide

EXAMPLES OF INSTALLATION POSITIONS

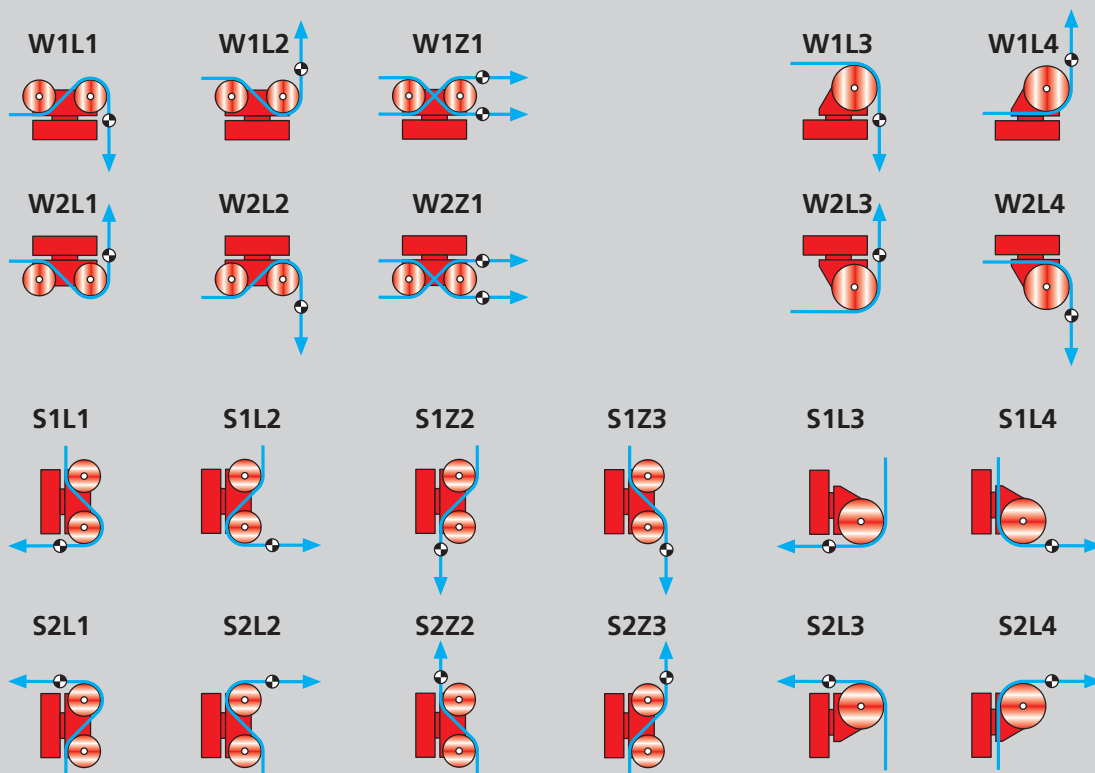

WEB GUIDING DEVICES

Guided unwinding/rewinding

Functionality

Sensors located on the machine frame (unwinding) or rewinding frame (rewinding) compare the target and actual position of the web. Deviations of the web position are corrected with lateral movement of the unwinding and/or rewinding frame.

Scope of application

- For unwinding and rewinding of rollers

Advantage

- Precise web infeed into the machine
- Generation of straight-edged material windings
- Minimum space requirement



Guided unwinding

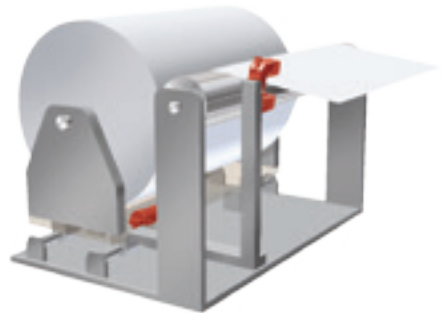

Guided rewinding

LAMINATING CONTROL

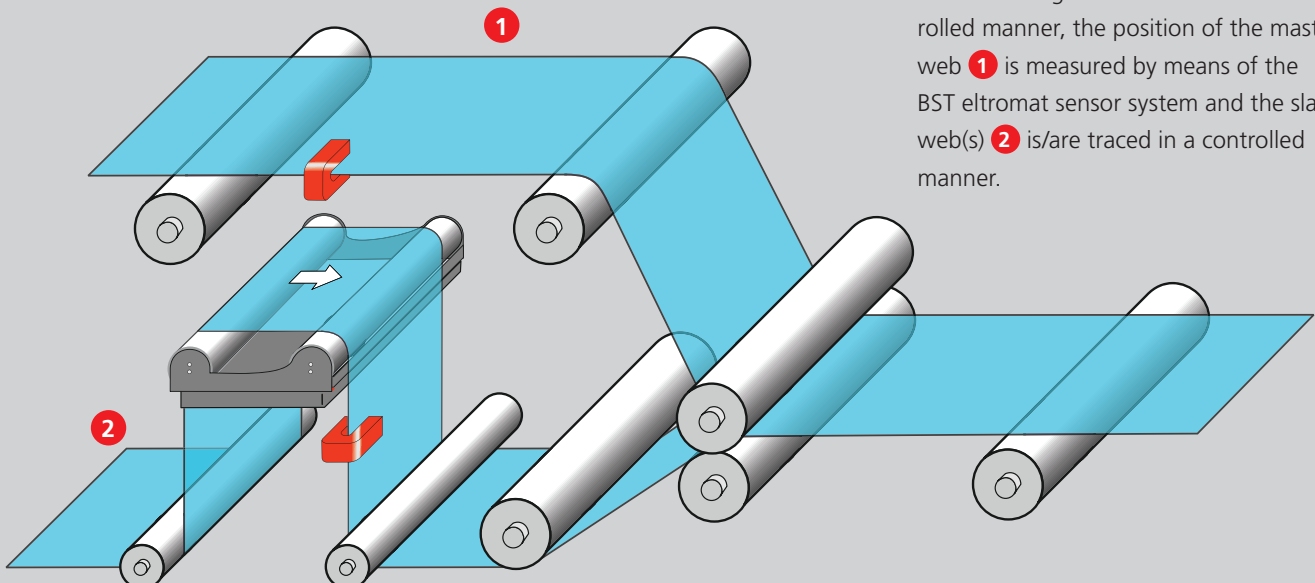

Functionality

For laminating several webs in a controlled manner, the position of the master web **1** is measured by means of the BST eltromat sensor system and the slave web(s) **2** is/are traced in a controlled manner.

EFFICIENT PRODUCTION. DIGITAL COMMUNICATION.

The variety of connectable components ensures optimal alignment with your application. All controllers offer ports for various connections: On the one hand for various sensors, guiding devices and actuators of different performance classes and on the other hand for the connection to your machine control.

BST eltromat web guiding systems provide you with information which you can directly integrate into your production process. But the system can also be controlled via your control system.

It determines the time-critical process data in real-time operation so you will always be informed about the current data of your entire system. Due to a simple internal and external networking, comfortable operation, extremely high interference resistance, fast and secure signal transmission as well as a minimum amount of cabling acc. to the simple plug & play feature, BST eltromat, in connection with your fieldbus system, offers a valuable contribution to your quality assurance.

For connecting the BST eltromat web guiding to all traditional bus systems (CAN-Bus, Profibus-DP, DeviceNet, Ethernet), you may choose among different gateways.

This technology is frequently used in different industries such as:

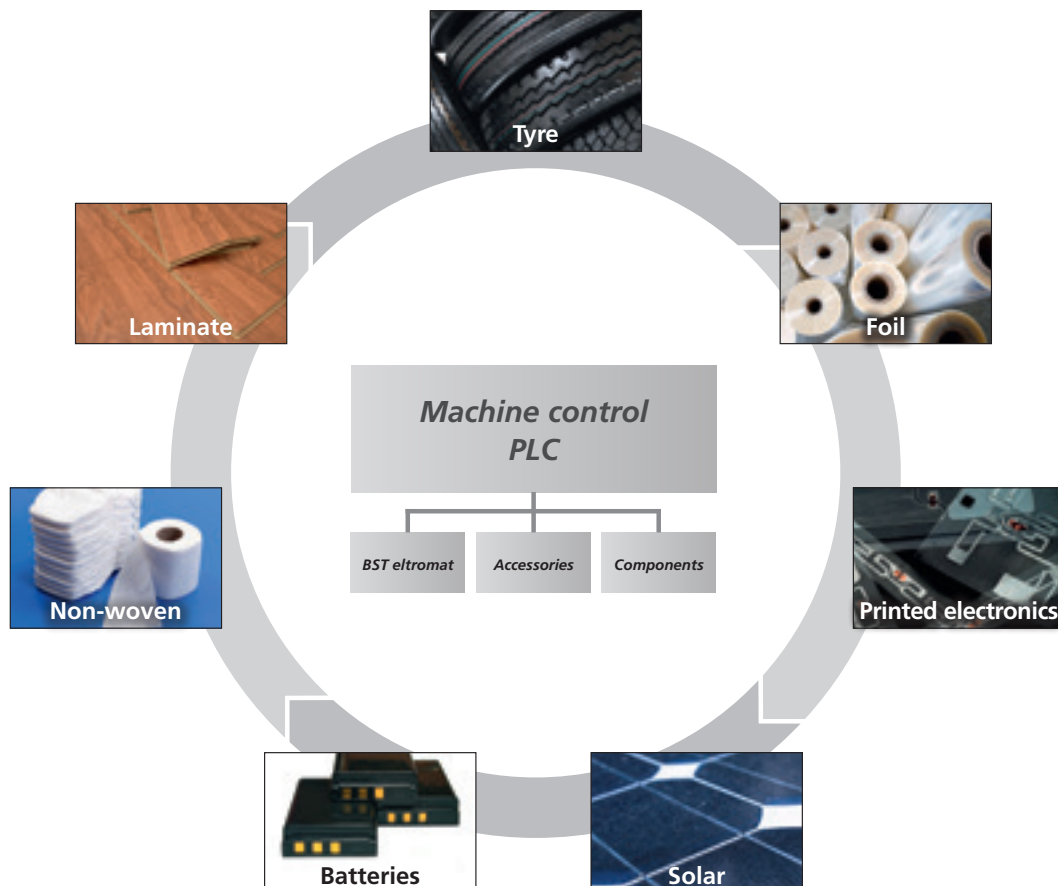

NOTES FOR YOUR CONFIGURATION.

Displacement Frame guide design

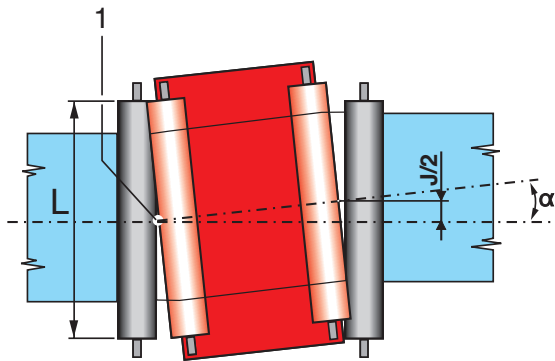
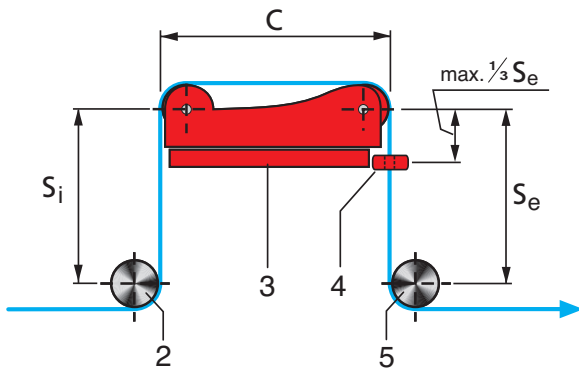

S_i = infeed span = 0.5 up to 1x (max.) material width
 S_e = exfeed span = 0.5 up to 1x (max.) material width

The designation of a displacement frame guide is as follows: **DF = n x D x L x C**

These are in detail:
Displacement frame guide (DF)
n = number of rollers
D = roller diameter
L = roller length
C = correction span

S_i = infeed span
 S_e = exfeed span
J = actuator stroke
 α = correction angle max. $\pm 5^\circ$

- 1 Pivot
- 2 Infeed roller
- 3 Rotating frame
- 4 Sensor
- 5 Exfeed roller



NOTES FOR YOUR CONFIGURATION.

Swivel Frame guide design

L enlacement

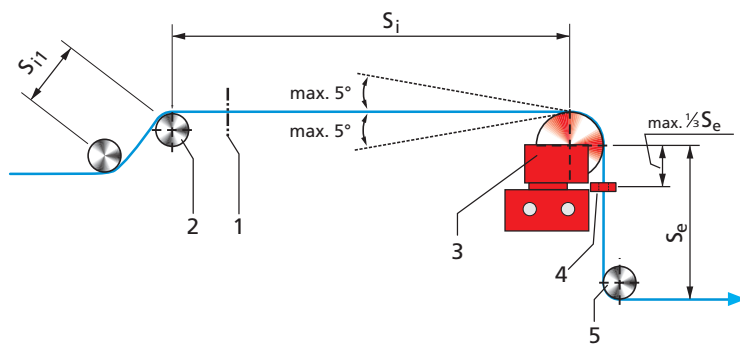

S_i = infeed span
= 1.8 up to 2x
(max.) material
width
 S_{i1} = pre-infeed span
 S_e = exfeed span
= 0.5 up to 1x
(max.)
material width

- 1 Fictive pivot
- 2 Infeed roller
- 3 Adjusting roll(s)
- 4 Sensor
- 5 Exfeed roller

W enlacement

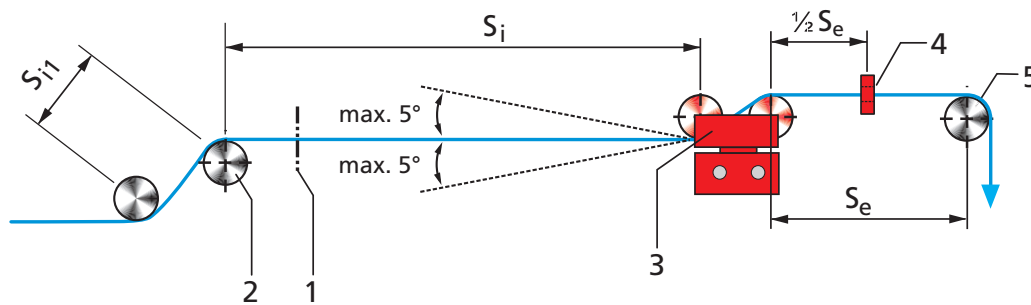

S_i = infeed span = 1.8 up to
2x (max.) material width
 S_{i1} = pre-infeed span
 S_e = exfeed span = 0.8 up to
1x (max.) material width

The designation of a swivel
frame guide is as follows:
SF = n x D x L

These are in detail:

SF = Swivel Frame guide
n = number of rolls
D = roller diameter
L = roller length

SPECIFICATIONS

Regarding the design of the BST eltromat web guiding system, the following specifications are required:

General data:

- Machine type
- Installation position
- Material
- Material thickness
- Material transparency (crystal clear, translucent, variable, reflective, opaque)
- Web width
- Web width deviations
- Web speed
- Web tension with maximum width
- Maximum infeed error
- Environment (normal, soiled, dusty)
- Ambient temperature
- Input supply voltage
- Operating mode (continuous, intermittent)

Scanning type:

- Web edge
- Web center-line
- Line
- Contrast

INTELLIGENT SERVICE THAT MOVES YOU FORWARD.

No matter where in the world you use our technologies: We support you reliably with our comprehensive BST eltromat service.

Our specialists are located all over the world and can be on site quickly in case of emergencies. You can access an extensive global production, sales and service network – for first-class performance at any location.

For your benefit, we always adapt our systems exactly to the requirements of your production. Combine solutions from our various product areas:

- Web Guiding
- 100% Inspection
- Register Control
- Web Video Inspection
- Color Measurement
- Surface Inspection
- Color Management
- Workflow
- Process Automation
- Layer Thickness & Basis Weight Measurement

Further information and current news are available at www.bst-international.com



Your local contact

Be inspired. Move forward.

BST eltromat GmbH
Heidsieker Heide 53 • 33739 Bielefeld • Germany
Tel.: +49 5206 999-0 • Fax: +49 5206 999-999 • info@bst-international.com

A member of the group of eLEXIS companies

© 2017 BST eltromat International • BST-eltromat_B303_0317_EN • Subject to change

 **BST eltromat**
INTERNATIONAL