

info@renova-srl.it - www.renova-srl.it

DESIGN @ COOPERA.COMPANY

CATCXENAA4V0517

# combirex PNEUMATIC BRAKE







Made in Italy



## INNOVATION DESIGNED TO LAST

*Renova provides class-leading products that increase the productivity and the safety level while reducing maintenance costs and procedures.*





## Fan

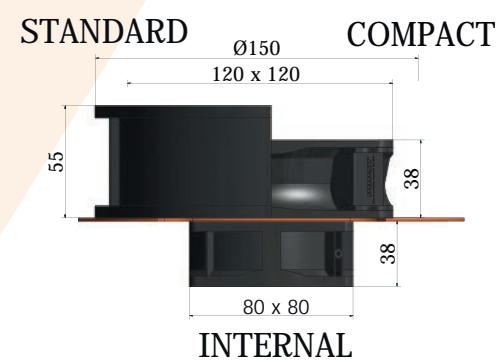

### UPGRADE KIT FAN COVER + FAN

MODEL	CODE
KIT HP1 (fan cover + INTERNAL 24Vdc HP1)	KVCX000000
KIT HP2 (fan cover + INTERNAL 24Vdc HP2)	KVCX0000H30
KIT HP3 (fan cover + INTERNAL 24Vdc HP3)	KVCX0000H40

### SPARE PARTS

MODEL	CODE
STANDARD (Ø150X55) 24 Vdc	VT15000024
STANDARD (Ø150X55) 220 AC	VT15000220
STANDARD (Ø150X55) 110 AC	VT15000110
COMPACT (120X120X38) 220 AC	VT12038220
COMPACT (120X120X38) 110 AC	VT12038110
COMPACT (120X120X38) 24 Vdc	VT12038024
COMPACT (120X120X38) 24 Vdc HP4	VT120380H4
COMPACT (120X120X38) 24 Vdc HP6	VT120380H6
INTERNAL (80X80X38) 24 Vdc HP1	VT80038024
INTERNAL (80X80X38) 24 Vdc HP2	VT800380H3
INTERNAL (80X80X38) 24 Vdc HP3	VT800380H4

## Disc



MODEL	CODE
Central disc hole 30 mm rough	DCCX250000
Disc hole 35mm for taper lock	DCCX250D35C
Disc hole 40mm for taper lock	DCCX250D40C
Disc hole 45mm for taper lock	DCCX250D45C
Disc hole 50mm with keyway	DCCX250D50K
Disc hole 60mm with keyway	DCCX250D60K

All other dimensions are available – customizable disc

# combirex CX250

Combirex CX250 pneumatic brake has been the reference brake in the converting industry and it is still widely used on unwinders and in various applications.

The CX250 has been designed by Giampiero Re, in the 1980s, who later founded the company, Renova, in 2005.

In the 1980's Mr. Re applied an innovative axial fan ventilation on the CX mono-disc brakes which helped to decrease the temperature faster than before. This led to a reduction of pad wear and an increased web tension quality compared to previous brakes without a cooling fan.

Today, the Renova CX pneumatic brake is the result of continuous research and improvements. Great importance is given to the selection of precise materials to reach and always provide a higher performance and less wear of components.

All Renova's products are managed by TUV ISO 9001



# combirex CX250

The combirex CX250 is a monodisc, multicaliper air cooled brake. It reaches a maximum torque of 960 Nm and a power dissipation of 4,5 kW.

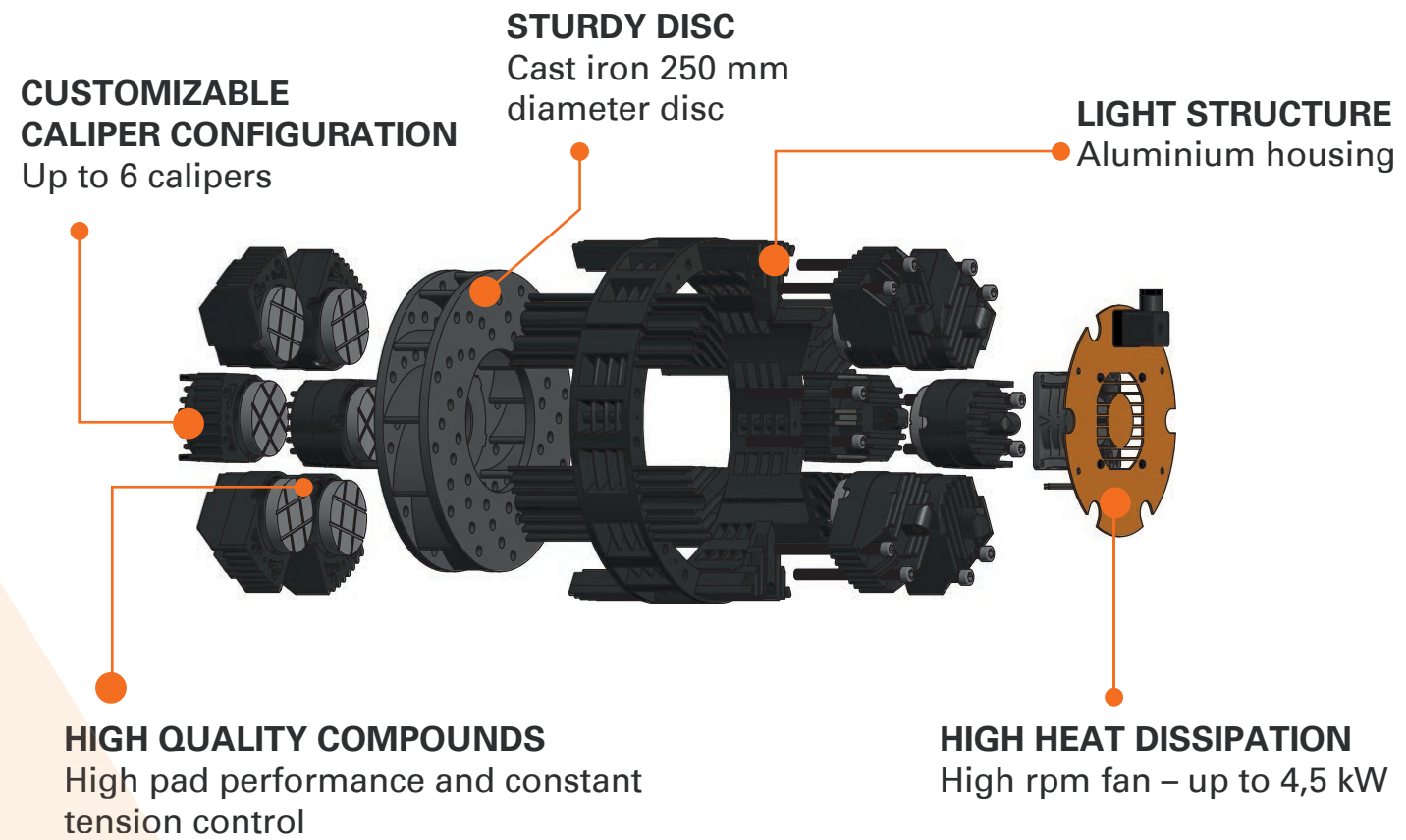

## NT

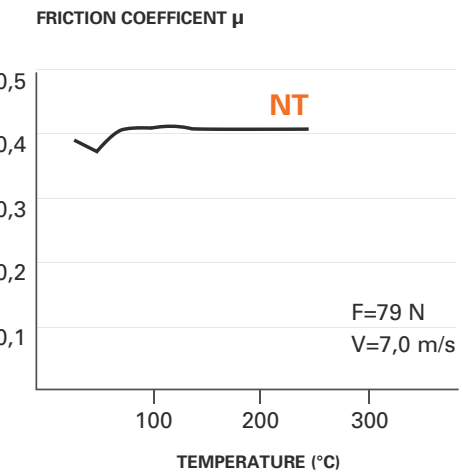

DESCRIPTION	CODE
Standard pads	KPCXNT
Standard pads with anti-vibration ring	KPCXNTA

## R-15

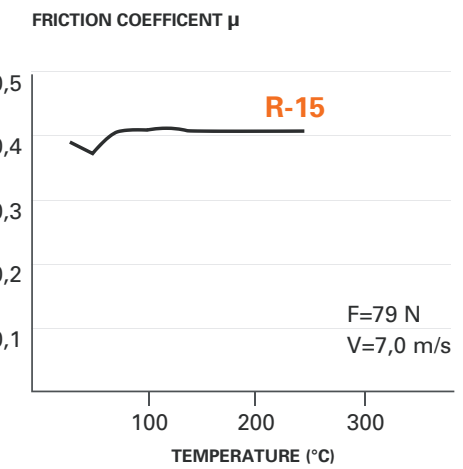

DESCRIPTION	CODE
Anti-rotation pads	KPCXR15
Anti-rotation pads with anti-vibration ring	KPCXR15A

## R-15K

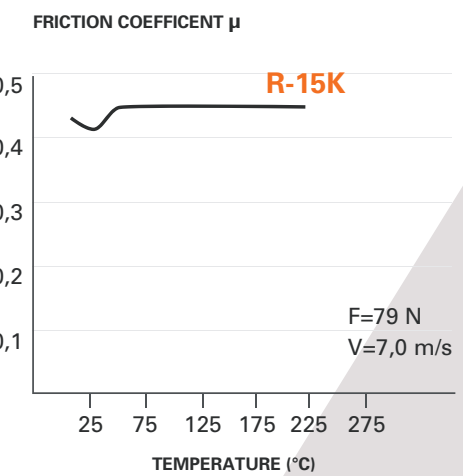

DESCRIPTION	CODE
Anti-rotation pads in Kevlar material	KPCXR15K
Anti-rotation pads in Kevlar material with anti-vibration ring	KPCXR15KA

### Kevlar

Guarantees high performance at high temperature



## Calipers

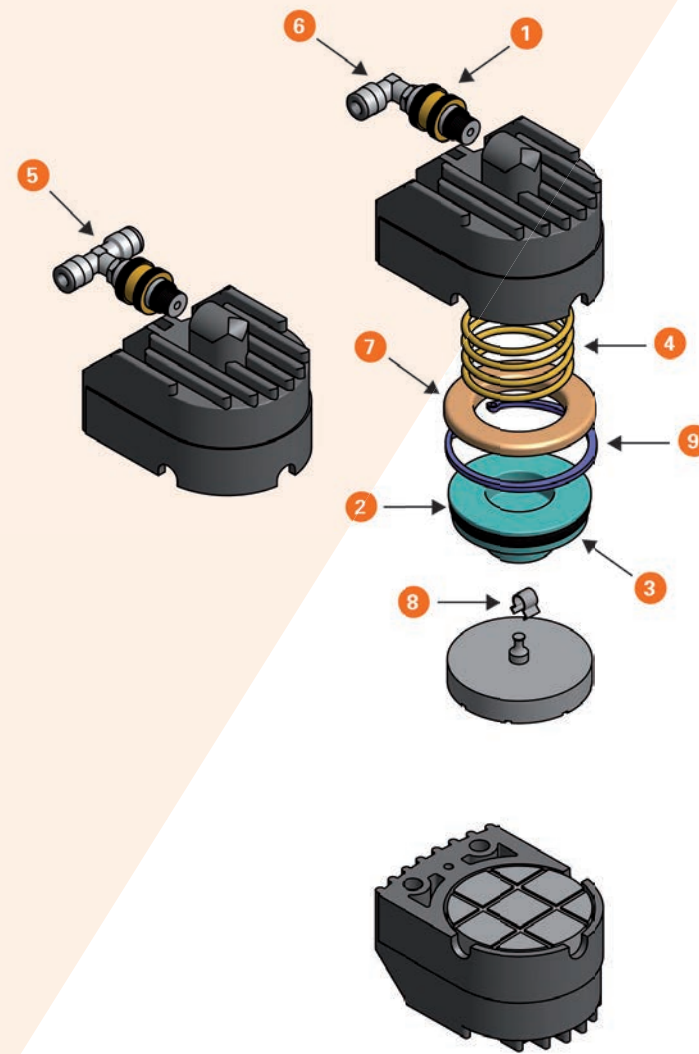

Description	Code
Complete caliper	00CX250P01
1 Selector	SELAIRCX250
2 Dem gasket	00DEM63250
3 Complete piston	00CXP25000
4 Spring	00CXMO8910
5 Rapid fitting TEE for capiper	00CXRT1080
6 Rapid fitting ELBOW for capiper	00CXRL1080
7 Locking ring	00CX250ANP
8 Pad spring	00CXMO9010
9 Seeger	00CXAS3065



## Pads

New and better performing pad models with a new compounds formula are available.

- Reduced powder emissions
- Longer life span of pads
- Higher performance

 **RoHs Compliant pads** – asbestos, hexavalent chromium, mercury, cadmium, antimony, lead FREE!

## Brake selection guide

	 Unit of measure	 Tensioning
$T_{\max / \min}$	max/min web tension [N]	$T_{\max} = T_s \cdot L_{\max}$ maximum web tension
$T_s$	web tension per centimeter [N/cm]	$T_{\min} = T_s \cdot L_{\min}$ minimum web tension
$D_{\max / \min}$	max/min roll diameter [m]	$Cf_{\max} = \frac{D_{\max} \cdot T_{\max}}{2}$ maximum torque
$L_{\max / \min}$	max/min web width [cm]	$Cf_{\min} = \frac{D_{\min} \cdot T_{\min}}{2}$ minimum torque
$m$	roll maximum weight [Kg]	$P = \frac{T_{\max} \cdot v}{60 \cdot 10^2}$ heat dissipated
$v$	web speed [m/min]	
$p$	heat dissipated [kW]	
$t$	breaking time [s]	 <b>Emergency stop</b>
		$Cf_{\max} = \frac{m \cdot D_{\max} \cdot v}{240 \cdot t}$ torque

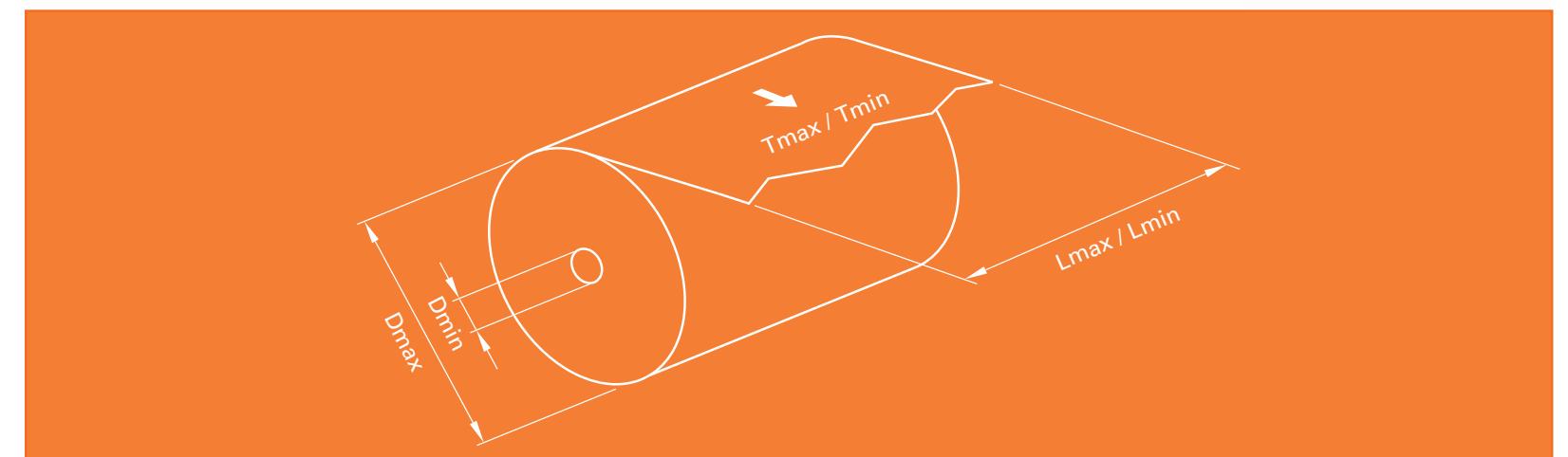

### Specific tension values for materials

<b>Paper</b> Weight g/m2 Web tension [N] per centimeter $T_s$	10 - 15 0,3 - 0,4	30 - 60 1 - 2,5	100 - 200 3,5 - 7
<b>Board</b> Weight g/m2 Web tension [N] per centimeter $T_s$	100 - 150 5 - 7,5	200 - 300 10 - 11,5	400 - 700 16 - 18
<b>Cellophane</b> N/cm for $\mu$ of thickness	0,042		
<b>Polyethylene</b> N/cm for $\mu$ of thickness	0,01 - 0,02		
<b>Polypropilene</b> N/cm for $\mu$ of thickness	0,015 - 0,025		
<b>Aluminium</b> N/cm for $\mu$ of thickness	0,035 - 0,105		

# Technical data

The combirex CX250 is available with up to 6 calipers according to the torque needed.

Moreover, a selection of diverse HP fan models is available in order to reach different heat dissipation values.

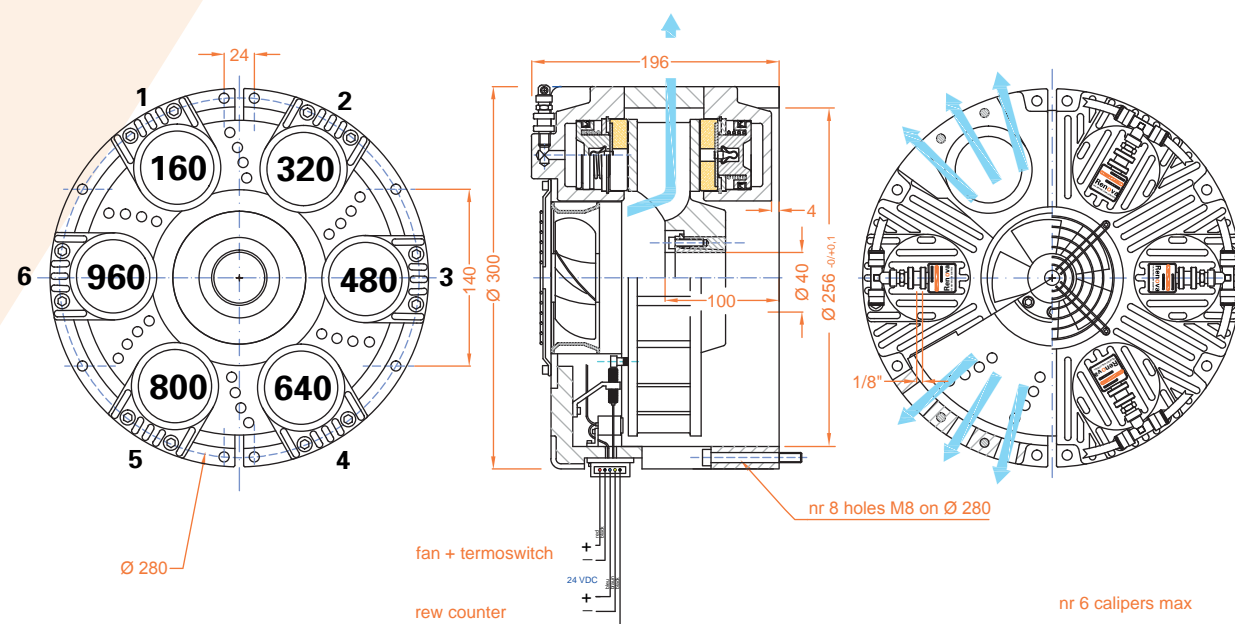

MODEL	NUMBER OF CALIBERS	TORQUE (Nm) 0,2 bar	TORQUE (Nm) 6 bar	HEAT DISSIPATION (kW)		
				Fan 24 Vdc HP1	Fan 24 Vdc HP2	Fan 24 Vdc HP3
CX 250.1	1	1,5	160			
CX 250.2	2	3	320			
CX 250.3	3	4,5	480	3,5	4	4,5
CX 250.4	4	6	640			
CX 250.5	5	7,5	800			
CX 250.6	6	9	960			

## CX250 spare parts

The CX250 has a wide range of spare parts that are also suitable for all of the CX250 brakes series available on the market.

Complete calipers or components, pads, fans and discs are all made of the highest quality material to ensure high life span of parts and better performance of the brake.

# 100% INTERCHANGEABLE

