

Maximum precision for your web

# BST Web Guiding



BST Web Guiding

# Optimized, Reliable, and High-Precision Web Guiding

Increasing production speeds and rising quality demands: In industries such as printing, modern production machines for the converting and finishing of web materials now operate at speeds that would have been considered extraordinary just a few years ago. At the same time, the only way for providers in the printing industry to remain competitive is to deliver reliable, accurate results.

## The Challenge

It is important to take full advantage of machine speeds while still ensuring that everything runs smoothly – from unwinding the material and guiding it through the production process to the final winding.

## Continuous and Precise Web Guiding

BST systems guide webs in a wide range of different production processes, such as in the paper, foil,

battery, and rubber industries, as well as in conveyor and transport systems. In the process, BST web guiding ensures that the material being converted is always in the precise position it is intended to be. BST web guiding systems can be used for many different types of substrates and effectively minimize waste and downtime.

## Contents

- 5 BST Guiding Devices
- 16 BST Controllers
- 22 BST Sensors
- 27 BST Actuators
- 30 Accessories
- 31 SMARTData



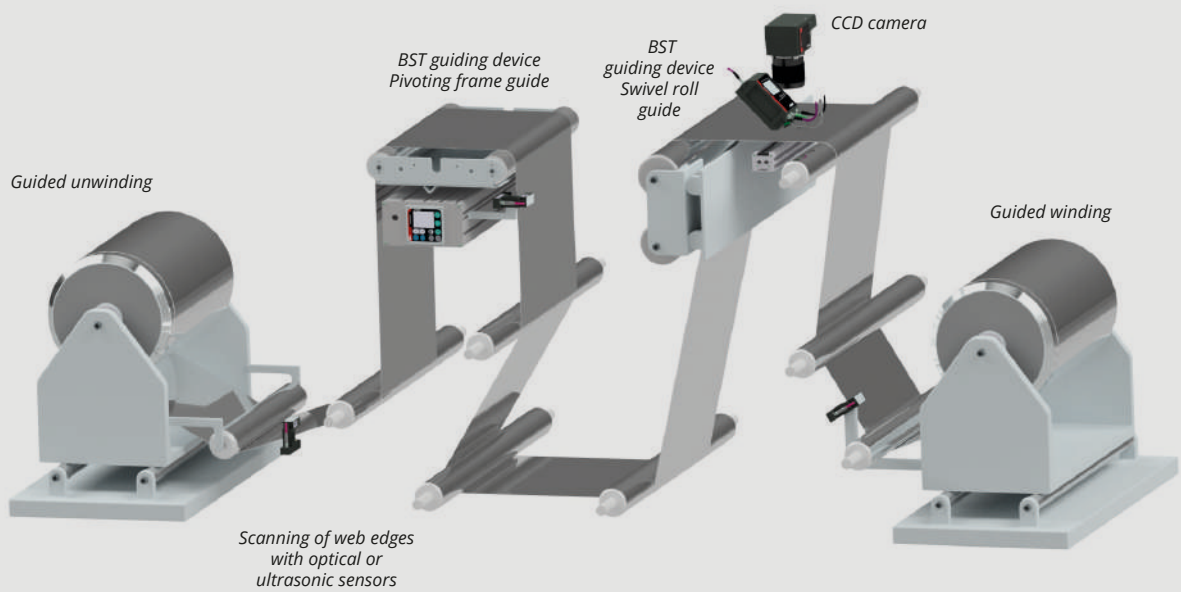

*Various applications for web guiding*

**Precise Corrections in Every Installation Position.**

In the web-processing industry, the material is usually supplied in rolls, unrolled for converting, run through the production process, and rolled up again at the end of the machine. These procedures often result in the web shifting, which is why web guiding secures the process at all critical points. What happens when the web position measured deviates from the target position? If the current mea-

sured position of the web deviates from its target position, the web guiding corrects until the target position is reached again. A number of different types of guiding devices can be used to achieve this, such as ECOGuide, COMPACTGuide, SMARTGuide, FRAMEGuide, or Winder packages.



# The Ideal Guide: The BST Cycle for Precision in Perfection

**Configured to your production:** BST web guiding systems are designed to meet the precise requirements of your production process in terms of their scope and degree of automation.

## Guiding Systems for Every Level of Converting

The structure of your production line will depend on the step of the converting process required for the web. Untreated webs can only be guided based on the web edge or web center, because there are generally no other characteristics on the web itself.

Finished webs, on the other hand, offer more options for sensor-based position monitoring using aspects such as printed lines, contrasts, or print images.

## Types of Web Guiding

In **web edge guiding**, guiding is based on the left or right web edge and uses an edge sensor. During the process of **web center-line guiding**, two edge sensors scan the position of the web center in order to use it as the basis for adjusting the position. **Contrast guiding** uses solid or broken printed lines or a contrast edge as a means





of orientation. **Object guiding** takes place directly in the print pattern using a camera and image processing with no additional trigger needed.

## Precision Based on Experience

As a leading manufacturer of quality assurance systems for the web-processing industry, BST has performed over 100,000 installations in more than 100 countries around the world.

## At a Glance: The BST Control Loop

All BST systems for web guiding are based on a closed control loop.

-  The **current position** of the web serves as the starting point.
-  It is recorded as the **current position** by one or more **sensors** and transmitted to the controller.
-  The **controller** compares these current values to the **target value** indicated. If the controller detects a discrepancy, it sends a corresponding **correction signal** to...
-  ...the **guiding device**, which corrects the position of the web precisely and almost instantaneously.

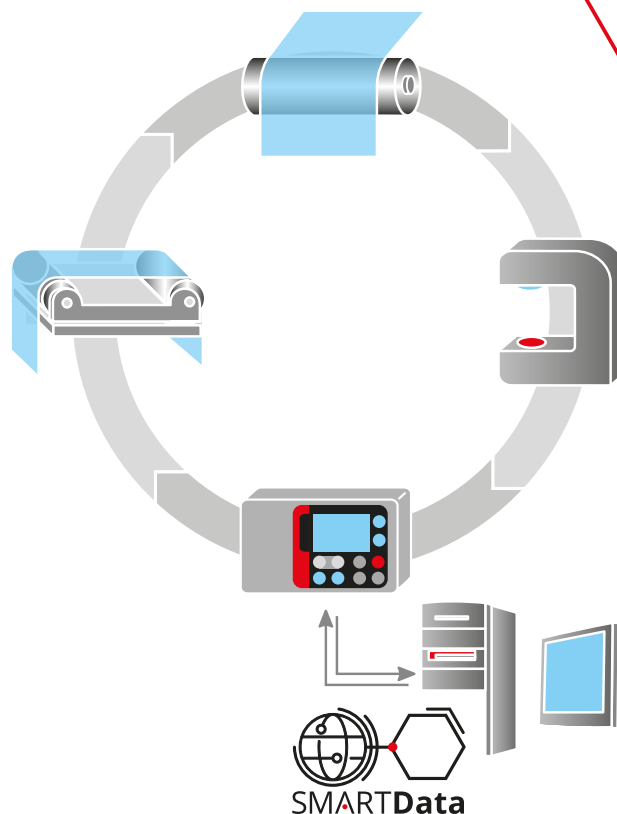



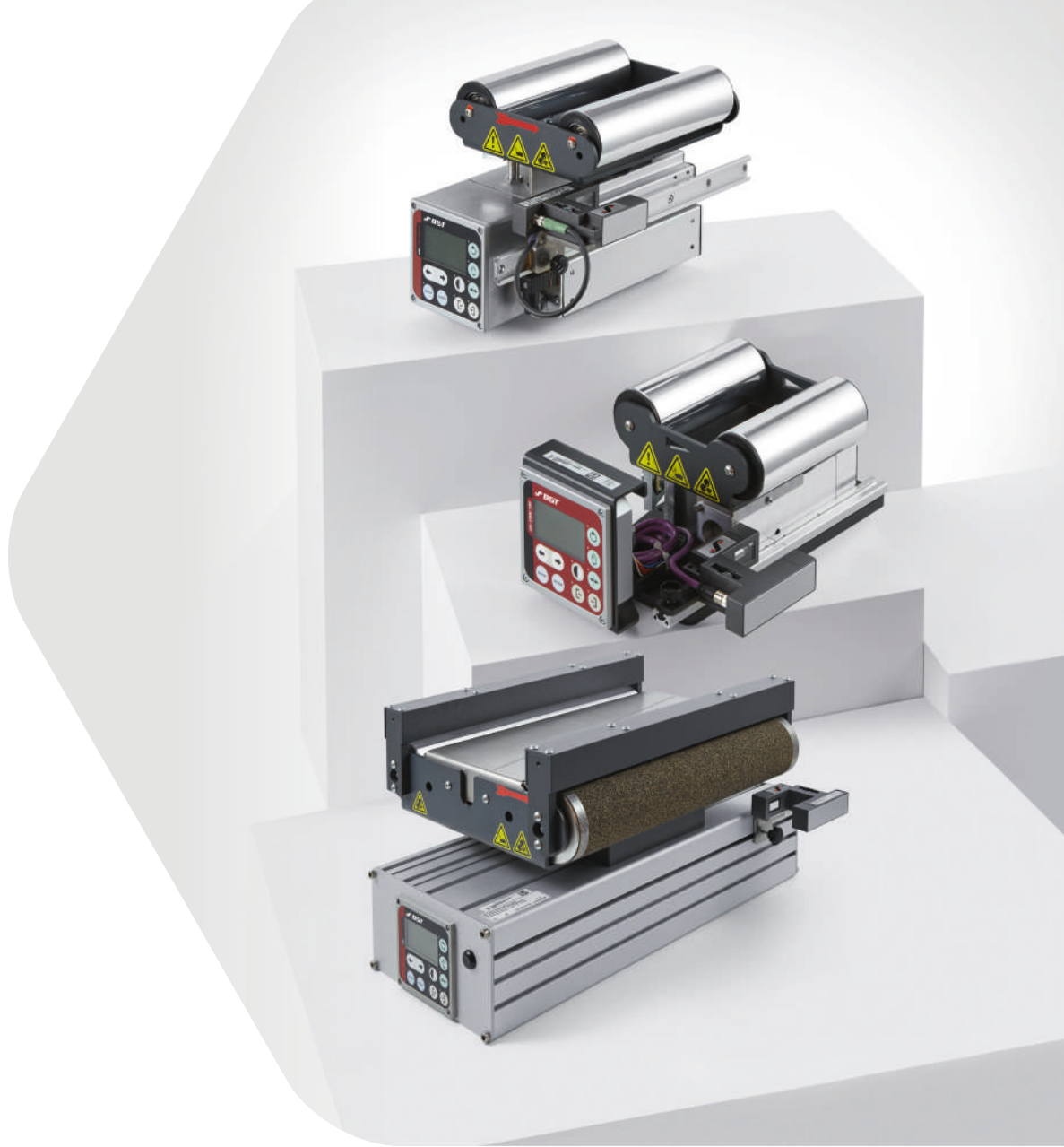

BST Guiding Devices

## Precise Web Correction for Every Need

BST guiding devices correct the position of the web precisely and almost instantaneously. In doing so, they play a central role in the smooth functioning of web guiding processes.

The guiding devices are deliverable in various sizes and types for almost all web widths and fields of application. In addition, a large number of roller designs and coatings are available for various types of material.

**Guiding devices can be flexibly implemented for your intended application, depending on these factors:**

- » Web width
- » Web tension
- » The material being converted and the stress it can tolerate
- » The space available in the machine

**Overview of BST guiding devices:**

- » ECOGuide
- » COMPACTGuide
- » SMARTGuide
- » FRAMEGuide
- » SPECIALGuide
- » Winder packages

**Contact us:**

We would be happy to provide you with expert advice right from the early development and concept phases of your project.



ECOGuide

BST Guiding Devices

# EcoGuide

## Cost-Effective Foundation for Your Web Guiding

The BST EcoGuide is ideally suited for guiding narrow webs. The packaging and non-woven industries are two of its most common fields of application.

With three different sizes and various specifications, the ECOGuide is individually configurable and extremely cost-effective to use. Thanks to its compact design and built-in controller, the system is easy to install, even in small spaces. Another significant benefit of the ECOGuide is its intuitive operation, which uses an ergonomic keyboard and provides direct access

to all important guiding functions. The maintenance-free, brushless drive allows for efficient operation, even in extreme conditions.

The ECOGuide is delivered ready for connection, reducing the effort required for installation and wiring to a minimum. It is suitable for use in all installation positions and with all threadings.

### System Equipment

- » All digital standard edge sensors can be implemented (optical or ultrasonic)
- » Choice of operating side
- » Guiding by web edge
- » Manual sensor adjustment
- » Remote control via digital inputs (digital I/O)

### Options

- » Guiding by web edge and web center (two edge sensors)

If you need further information about your individual version, your contact at BST will be happy to help.

|                 |                         |           | Web widths      | 10-520 |     |     |     |     |     |
|-----------------|-------------------------|-----------|-----------------|--------|-----|-----|-----|-----|-----|
| ECOGuide<br>1-3 | Max. web tension        | 300 N     | Roller length   | 150    | 250 | 300 | 350 | 450 | 550 |
|                 | Max. web speed          | 500 m/min | Correction span | 180    | 200 | 250 | 300 |     |     |
|                 | Max. web position error | ± 17 mm   | Roller diameter | 60     |     |     |     |     |     |



COMPACTGuide 1-3

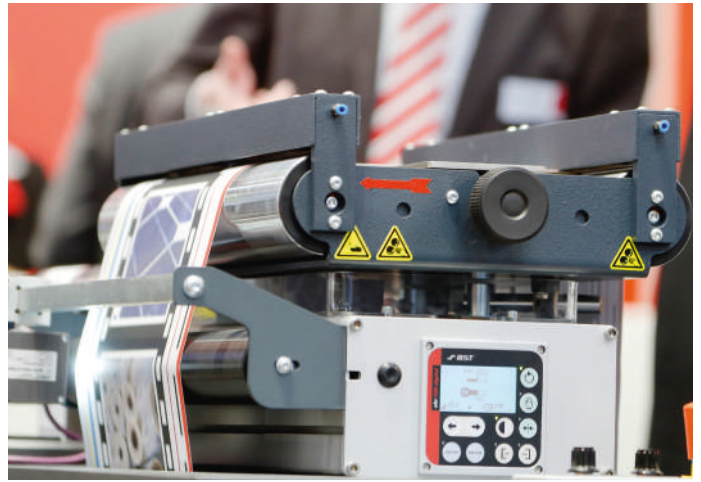

COMPACTGuide 4-6

## BST Guiding Devices

# COMPACTGuide Precise Web Guiding in the Smallest Space

BST COMPACTGuide web guiding is ideal for use with narrow material webs, especially in the label, packaging, and non-woven industries.

The COMPACTGuide comes in six different sizes, so you will always be able to find the perfect version to meet your requirements. Its compact, modular design and integrated controller allow for easy installation, even in small spaces. The removable ergonomic control panel makes operation simple and intuitive while providing fast, direct access to all important guiding functions. The ready-to-connect design

minimizes the effort required for installation and wiring. The COMPACTGuide is suitable for use in all installation positions and with all threadings.

### System Equipment

- » Reliable guiding by web edge and web center
- » Suitable for use with all digital web edge sensors (optical or ultrasonic)
- » Removable/expandable control panel
- » Choice of operating side
- » Manual sensor adjustment
- » Remote control via digital inputs (digital I/O)

### Options

- » Manual fine tuning for one or both edge sensors
- » Line and contrast guiding with CLS PRO 600
- » Object guiding with CLS CAM 100
- » Remote control via second commander
- » Splice table incl. clamping devices (pneumatic or mechanical)
- » COMPACTGuide net incl. fieldbus module

If you need further information about your individual version, your contact at BST will be happy to help.

|                  |                         |           | Web widths      | 10-420 |     |     |     |     |     |     | 350-750 |     |         |  |  |
|------------------|-------------------------|-----------|-----------------|--------|-----|-----|-----|-----|-----|-----|---------|-----|---------|--|--|
| COMPACTGuide 1-3 | Max. web tension        | 300 N     | Roller length   | 160    | 200 | 250 | 300 | 350 | 400 | 450 |         |     |         |  |  |
|                  | Max. web speed          | 600 m/min | Correction span | 180    | 200 | 250 | 300 |     |     |     |         |     |         |  |  |
|                  | Max. web position error | ± 17 mm   | Roller diameter | 40     | 60  | 80  |     |     |     |     |         |     |         |  |  |
| COMPACTGuide 4-6 | Max. web tension        | 600 N     | Roller length   |        |     |     |     |     | 400 | 450 | 500     | 550 | 600-800 |  |  |
|                  | Max. web speed          | 600 m/min | Correction span |        |     |     |     |     | 300 | 350 | 400     | 450 | 500     |  |  |
|                  | Max. web position error | ± 25 mm   | Roller diameter |        |     |     |     |     | 80  |     |         |     |         |  |  |



# SMARTGuide – Tried and Tested Solutions for Optimal Web Guiding

The SMARTGuide’s main applications are printing and extrusion.

This web guiding system is also especially well-suited for short closed loops with low material stress. The sensors can be moved by optional motor-driven sensor adjustment for ease of use. This is especially useful when working with sensors that are difficult to access, frequent changes in web width, or special functions such as oscillation.

You will benefit from proven standards and a wide variety of equipment features: Thanks to the SmartGuide’s modular design, customer-specific solutions can be implemented particularly efficiently. Simple retrofits are also possible at any time. The predefinition of characteristics ensures maximum transparency and simplifies technical clarifications.

### System Equipment

- » Reliable guiding by web edge and web center
- » Suitable for use with all digital web edge sensors (optical or ultrasonic)
- » Choice of operating side
- » Manual sensor adjustment
- » Remote control via digital inputs (digital I/O)

### Options

- » Manual fine tuning for one or both edge sensors
- » Object guiding with CLS CAM 100
- » Line and contrast guiding with CLS PRO 600
- » Remote control via additional commander
- » Motor-driven sensor adjustment with automatic edge finding and pre-positioning for edge and/or web center-line guiding with a set or variable web center
- » Optional bus systems: CAN, Profibus DP, Profinet, Powerlink, Ethercat, or Ethernet UDP



SMARTGuide Size M

If you need further information about your individual version, your contact at BST will be happy to help.

|                          |                         |           | Web widths      | 750-1750 |     |      |      |      |      |      | 900-3400 |      |           |      |
|--------------------------|-------------------------|-----------|-----------------|----------|-----|------|------|------|------|------|----------|------|-----------|------|
| <b>SMARTGuide Size M</b> | Max. web tension        | 1000 N    | Roller length   | 800      | 900 | 1000 | 1100 | 1200 | 1300 | 1400 | 1500     | 1600 | 1700      | 1800 |
|                          | Max. web speed          | 800 m/min | Correction span | 800      | 900 | 1000 | 1100 | 1200 |      |      |          |      |           |      |
|                          | Max. web position error | ± 25 mm   | Roller diameter | 120      | 160 |      |      |      |      |      |          |      |           |      |
| <b>SMARTGuide Size L</b> | Max. web tension        | 1000 N    | Roller length   |          |     | 1000 | 1100 | 1200 | 1300 | 1400 | 1500     | 1600 | 1700-3500 |      |
|                          | Max. web speed          | 800 m/min | Correction span |          |     | 1400 | 1500 | 1600 | 1700 | 1800 | 1900     | 2000 |           |      |
|                          | Max. web position error | ± 50 mm   | Roller diameter |          |     | 120  | 160  | 200  |      |      |          |      |           |      |

# FRAMEGuide

## Maximum Precision in the Smallest Space

The FRAMEGuide's main applications are in the printing and battery industry.

The FRAMEGuide offers highly accurate guiding results combined with an impressively low installation height. This makes our systems the perfect choice for integration into your machine layout – just like the optional, motor-driven sensor adjustment system. The fixed and moving parts of the frame are arranged on one level to provide maximum flexibility when it comes to installing the system in your machine. The optimized layout of the FRAMEGuide provides maximum guiding precision.

The FRAMEGuide is suitable for use in all installation positions and with all threadings. The sensors can be moved by optional motor-driven sensor adjustment for ease of use.

The high-precision version of the FRAMEGuide features a highly dynamic brushless actuator in combination with components with minimal play, making it possible to achieve guiding accuracies of the highest level.

### System Equipment

- » Reliable guiding by web edge or web center
- » Suitable for use with all web edge sensors (optical or ultrasonic)
- » Choice of operating side
- » Manual sensor adjustment
- » Remote control via digital inputs (digital I/O)

### Options

- » Manual fine tuning for one or both edge sensors
- » Object guiding with CLS CAM 100
- » Line and contrast guiding with CLS PRO 600
- » Remote control via additional commander
- » Motor-driven sensor adjustment with automatic edge finding and pre-positioning for edge and/or web center guiding with a set or variable center line
- » Optional bus systems: CAN, Profibus DP, Profinet, Powerlink, Ethercat, or Ethernet-UDP
- » High-precision variant for maximum guiding accuracy



FRAMEGuide Size M

If you need further information about your individual version, your contact at BST will be happy to help.

|                      |                         |           | Web widths      | 750–1750 |      |      |      |      |      |      | 900–3400 |      |      |  |
|----------------------|-------------------------|-----------|-----------------|----------|------|------|------|------|------|------|----------|------|------|--|
| FRAMEGuide<br>Size M | Max. web tension        | 1000 N    | Roller length   | 900      | 1000 | 1100 | 1200 | 1300 | 1400 | 1500 | 1600     | 1700 | 1800 |  |
|                      | Max. web speed          | 800 m/min | Correction span | 800      | 900  | 1000 | 1100 | 1200 | 1300 | 1400 |          |      |      |  |
|                      | Max. web position error | ± 50 mm   | Roller diameter | 90       | 120  | 160  |      |      |      |      |          |      |      |  |

The FRAMEGuide Size S variant is available for web widths ranging from 350 to 950 mm.

BST Guiding Devices

# SPECIALGuide Optimized, Reliable Web Guiding

## **SPECIALGuide: Maximum Flexibility for Your Application**

SPECIALGuide is the solution for the most diverse requirements and framework conditions. By SPECIALGuide, we mean the 100 % customized solution for your web guiding application. Whether you're looking for a swivel roll guide, a turning bar guide, or web guiding tailored exactly to your application, we offer you the opportunity to work alongside our

experts to find the perfect solution. Benefit from a wide range of solutions designed to guide your web reliably and precisely at all times.

**SPECIALGuide is the BST modular system for maximum flexibility combined with the decades of experience of our web guiding experts. Contact us today!**





# Winder Packages Precise Winding Results – Exact Position Guiding

**BST winder packages are used in virtually all applications.**

Guided winding and unwinding ensures that shifts in the web position are precisely balanced and effectively minimizes the potential for errors. Tried and tested BST system components and a virtually unlimited range of options provide optimal solutions for customers at an affordable price. For example, line and contrast guiding are optionally available with our CLS

PRO 600 or object controls with the CLS CAM 100 object sensor.

The modular design of the BST winder packages allows expansions to be retrofitted at any time. The predefinition of the characteristics simplifies technical clarification processes and increases transparency.

Winder packages control the guiding device directly, allowing them to be integrated into your machine in a particularly simple and space-saving manner

**Benefits:** Infinite variations thanks to a wide range of controllers, sensors, and actuators

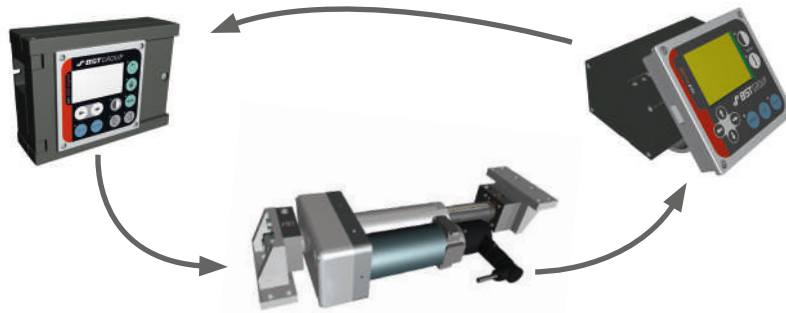

If you need further information about your individual version, your contact at BST will be happy to help.

|                              |                         |          |                         |     |     |     |
|------------------------------|-------------------------|----------|-------------------------|-----|-----|-----|
| <b>Winder package Size 1</b> | Max. positioning force  | 840 N    | Positioning stroke (mm) | 50  | 100 | 200 |
|                              | Max. adjustment speed   | 20 mm/s  | Adjustment speed (mm/s) | 10  | 20  |     |
|                              | Max. web position error | ± 100 mm |                         |     |     |     |
| <b>Winder package Size 2</b> | Max. positioning force  | 1680 N   | Positioning stroke (mm) | 100 | 195 |     |
|                              | Max. adjustment speed   | 20 mm/s  | Adjustment speed (mm/s) | 10  | 20  |     |
|                              | Max. web position error | ± 100 mm |                         |     |     |     |
| <b>Winder package Size 3</b> | Max. positioning force  | 2250 N   | Positioning stroke (mm) | 195 |     |     |
|                              | Max. adjustment speed   | 20 mm/s  | Adjustment speed (mm/s) | 10  | 20  |     |
|                              | Max. web position error | ± 100 mm |                         |     |     |     |
| <b>Winder package Size 4</b> | Max. positioning force  | 10,000 N | Positioning stroke (mm) | 195 | 295 |     |
|                              | Max. adjustment speed   | 20 mm/s  | Adjustment speed (mm/s) | 10  | 20  |     |
|                              | Max. web position error | ± 150 mm |                         |     |     |     |



*Guided unwinding*

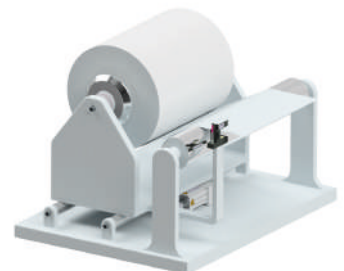

*Guided winding*

# Precise Web Correction in Every Installation Position

## Forward-Thinking Technology That Helps You Advance.

Our solutions result from detailed discussions with you: We will be by your side to support you during your initial project planning and design phase and throughout all of your decision-making processes; we are happy to contribute our extensive expertise and our equally extensive passion for perfection. You benefit from tailor-made systems that perform

reliably every time you use them. BST web guiding systems are always oriented towards their respective application, with various designs and guide types to choose from. In order to explain the functions in more detail, we have listed the most important terms used in web guiding below.

## Requirements

Information on the following points is helpful to facilitate communication with our web guiding experts:

### General Data:

- » Type of machine
- » Installation site
- » Material
- » Material thickness
- » Transparency of material (transparent, translucent, variable, reflective, opaque)
- » Web width
- » Variations in web width
- » Web speed
- » Web tension at maximum width
- » Maximum incoming defects
- » Environment (normal, dirty, dusty)
- » Ambient temperature
- » Connection voltage
- » Type of operation (continuous, intermittent)

### Type of Scanning:

- » Web edge
- » Web center
- » Line
- » Contrast

# Guiding Types and Their Applications

This is where we have summarized the different types of web guiding and explained them in more detail so that you can communicate with us more efficiently.

## Pivoting Frame Guide (DF)

The BST pivoting frame guide consists of a fixed lower frame and a rotatable upper frame, which pivots at the entry point of the web. This guiding device is used if the path of the web has to be corrected in a short closed loop with extremely low material stress. Further benefits include the variable installation positions and the low positioning force.

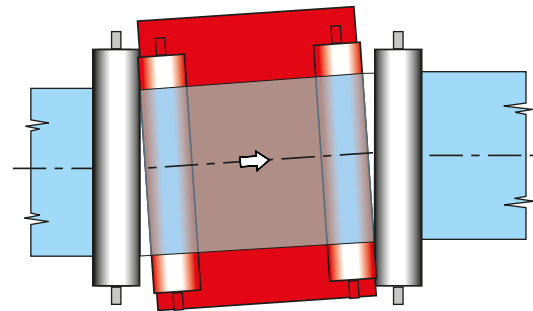
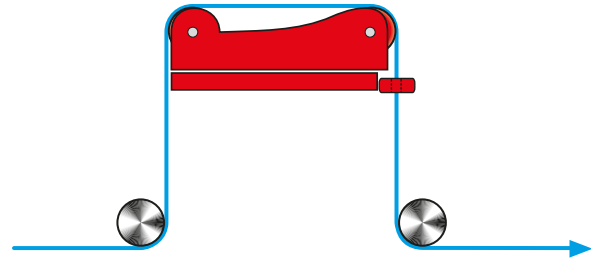

How the pivoting frame guide functions

## Pivoting Frame Guide Setup

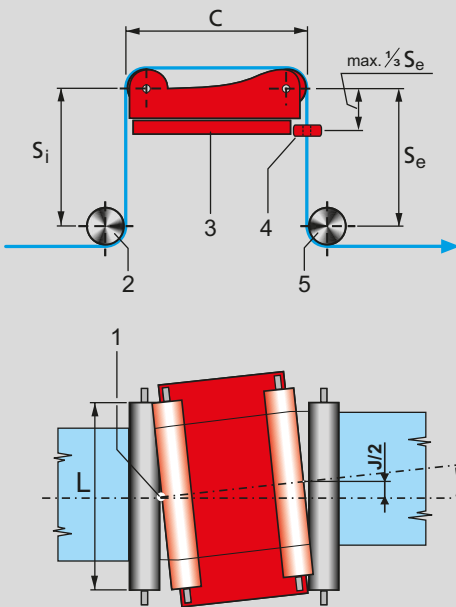

## Examples of Installation Positions

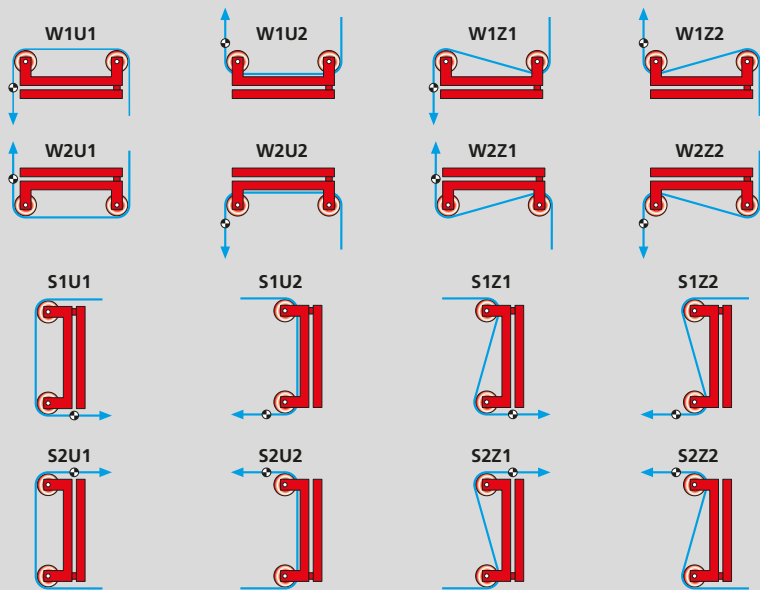

$S_i$  = Entry span = 0.5 to 1x max. material width  
 $S_e$  = Exit span = 0.5 to 1x max. material width

The pivoting frame guide is labeled as follows: **DF n x D x L x C**

It comprises the following parts:

- DF** = Pivoting frame guide
- n** = Number of rollers
- D** = Diameter of rollers
- L** = Length of rollers
- C** = Correction span

- $S_i$  = Entry span
- $S_e$  = Exit span
- J** = Stroke of the actuator
- $\alpha$  = Correction angle max.  $\pm 5^\circ$

- 1** Pivot
- 2** Entry roller
- 3** Pivoting frame
- 4** Sensor
- 5** Exit roller



# Guiding Types and Their Applications

## Swivel Roll Guide (SF)

The BST swivel roll guide consists of a fixed lower frame and a pivotable upper frame with one or two casters. This guiding device requires sufficiently long entry and exit spans in order to function properly. Swivel roll guides are implemented if installation space is limited, if the required web threading does not allow for the use of a pivoting frame guide, or if the web continually drifts off to the side (integral correction).

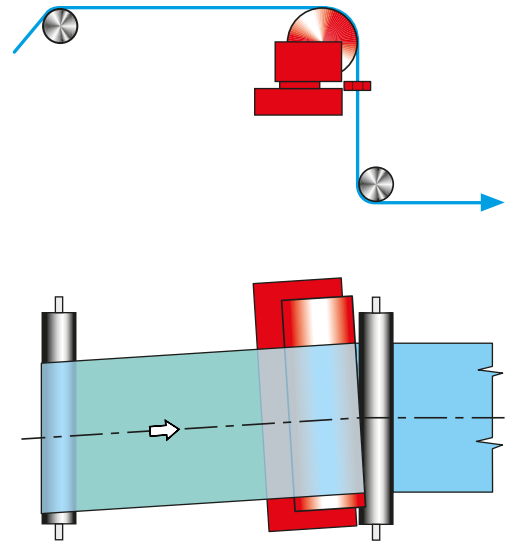

How the swivel roll guide functions

## Swivel Roll Guide Setup

- $S_i$  = Entry span = 1.8 to 2x max. material width
- $S_{i1}$  = Pre-entry span
- $S_e$  = Exit span = 0.5 to 1x max. material width
- 1 Virtual pivot
- 2 Entry roller
- 3 Caster(s)
- 4 Sensor
- 5 Exit roller

### L-winding

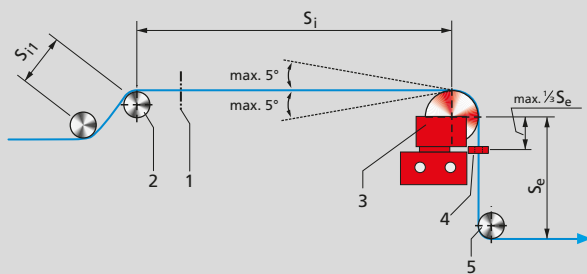

### W-winding

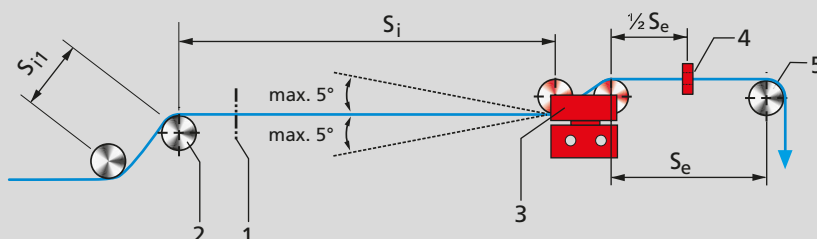

## Examples of Installation Positions

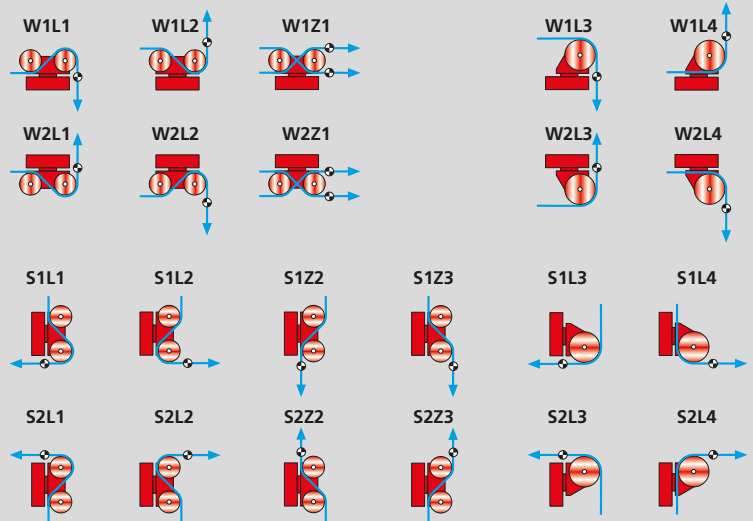

- $S_i$  = Entry span = 1.8 to 2x max. material width
- $S_{i1}$  = Pre-entry span
- $S_e$  = Exit span = 0.8 to 1x max. material width

The swivel roll guide is labeled as follows: **SF = n x D x L**

It is comprised as follows:

- SF** = Swivel roll guide
- n** = Number of rollers
- D** = Diameter of rollers
- L** = Length of rollers

### Guided turning bar

The turning bar is used in all cases in which a 90° turn in the web with simultaneous web guiding is required. The turning bar is installed at a 45° angle to the entry/exit direction of the web. The web winds itself around the turning bar at an angle of 180° and exits the guiding device at a right angle to the entry position.

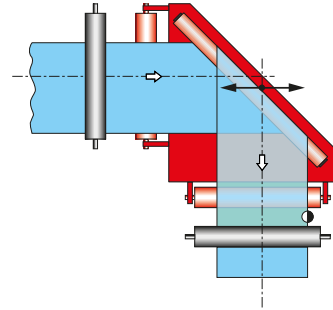

*How the turning bar functions*

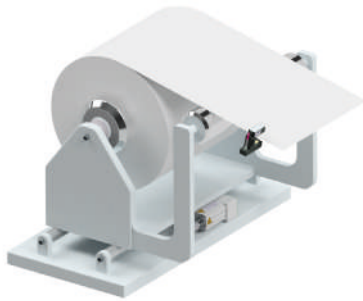

*Guided unwinding*

### Guided winding and unwinding

Sensors on machine frame (unwinding) or winding frame (winding) compare the current and target position of the web. Variations in the web position are guided by lateral tracking of the unwinding/winding frame. The advantage of integrating BST web guiding into your machine frame is that it takes up minimal space.

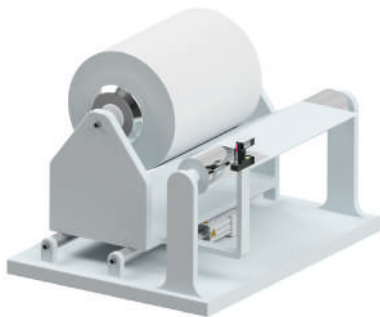

*Guided winding*





BST ekr CON 100 controller

## BST Controllers

# ekr CON 100 Easy Handling for Reliable Results



„Connect and go. Simple and pragmatic from commissioning to operation and service, BST controllers are perfectly designed for the operator. With numerous integration and networking options, they can be used for basically any web guiding application.“

*Ingo Ellerbrock,  
Head of Product Management*

With real user-friendliness and outstanding precision, the ekr CON 100 ticks all the boxes.

As a controller for all basic web guiding applications, this controller is extremely versatile and fulfils all the necessary functions with maximum reliability. Commissioning is quick and easy thanks to the plug-and-play function. Plug connections enable effortless connection processes at any time. Digital edge sensors can be effortlessly integrated into the system. A first-class price-performance ratio makes the ekr CON 100 an attractive solution for all conventional web guiding applications.

### **ekr CON 100 – Your Benefits at a Glance:**

- » Rapid commissioning (plug & play)
- » Easy interchangeability
- » Straightforward handling and user guidance
- » Service via USB
- » Remote control via digital inputs



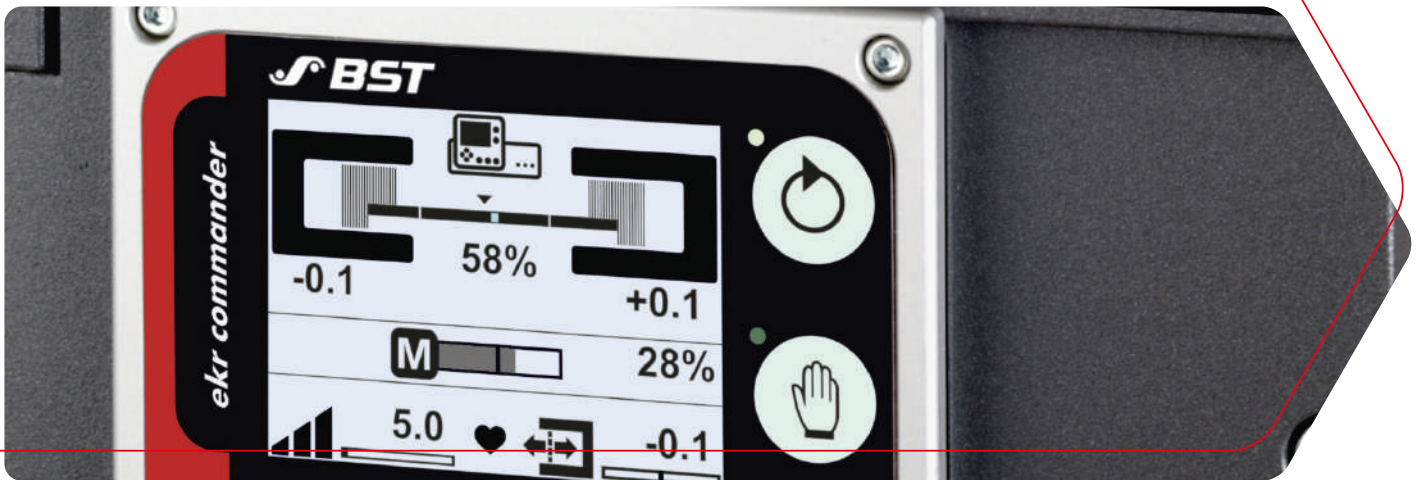

ekr CON 600

## BST Controllers

# ekr CON 600

## Intuitive, Pioneering, Functional

The functional scope of the ekr CON 600 controllers and their predecessor, the ekr 500 Digital Unit Touch, are tailored to suit classic web guiding tasks.

Both controllers offer impressive user-friendliness and low-cost commissioning and operation. The compact design of the controllers and removable control panel (ekr commander) offer convenient operation, even when installed in locations that are not easily accessible.

The clear LC touchscreen display graphically displays all the relevant data, such as web position, sensor coverage, and actuator position. As for the control panel, this can be mounted in any position to offer universal handling, cut down on cables, and enable straightforward wiring. An electrically isolated CAN bus is used for networking with other BST controllers or for machine control by the customer. The service interface works by means of a USB port.

### ekr CON 600 – Your Benefits:

- » Rapid commissioning (plug & play)
- » Easy interchangeability
- » Simple handling
- » Service via USB
- » Removable control panel incl. color LC touchscreen display
- » CAN stroke technology
- » Connection possibility for additional commander for second control point (optional)
- » Remote control via digital inputs
- » Digital outputs
- » Analog input – e.g., for machine speed
- » Connection possibility for motor-driven sensor adjustment type FVG POS 100
- » Oscillation
- » Web width measurement
- » Inclusion of QR codes in the display for the use of BST.Help
- » Share service data with the help desk via QR code

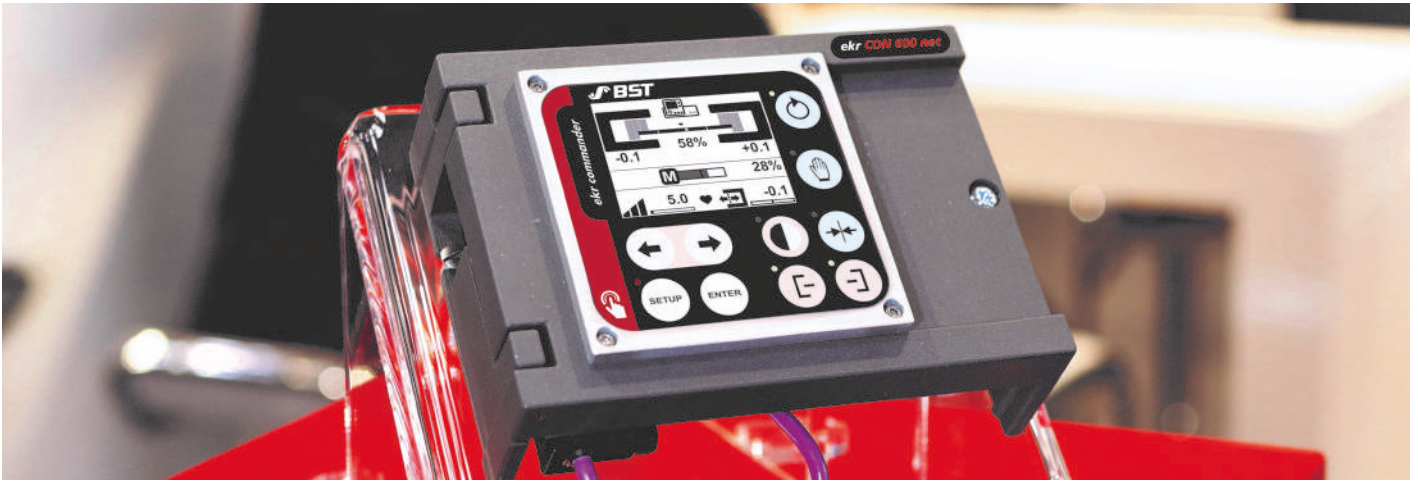

ekr CON 600 net

## BST Controllers

# ekr CON 600 net Intuitive Connectivity

The functional scope of the ekr CON 600 net controller is tailored to suit classic web guiding tasks. The ekr CON 600 net offers impressive user-friendliness along with low-cost commissioning and operation. Its integrated fieldbus interface makes it compatible with common bus systems to facilitate deep integration into your machine's PLC.

The ekr CON 600 net uses the ekr commander from the ekr CON 600 and ekr 500 Digital Unit Touch to ensure a consistent operating philosophy and easy interchangeability.

The clear LC touchscreen display graphically displays all the relevant data, such as web position, sensor coverage, and actuator position. As for the control panel, this can be mounted on the machine in any position to offer universal handling, cut down on cables, and enable straightforward wiring.

Integrated fieldbus modules are used for networking with other BST controllers or with a customer's machine controller. The service interface works by means of a USB port.

### ekr CON 600 –

#### Your Benefits at a Glance:

#### (supplementary to the ekr CON 600):

- » Secure and fast data transmission
- » Connection to various bus systems via integrated fieldbus modules
- » Intuitive networking via various interfaces
- » Tried and tested operating concept for maximum ease of use
- » 100 % backward compatibility with ekr 500 Digital applications
- » Simple communication with your machine
- » Possible fieldbus systems: CANopen, Profibus DP, Profinet; Ethernet UDP, Powerlink, or EtherCAT

### Note for ekr CON 600 and ekr CON 600 net

If required, the ekr CON 600 and ekr CON 600 net controllers can display a QR code for easy access to the operating instructions using a mobile end device. This can also be used to share controller status information with our helpdesk.

# BST Controllers

## Overview

|   | ekr CON 100 | ekr 500 Digital Unit Touch<br>& ekr CON 600               | ekr CON 600 net                     |
|---|-------------|---|-------------------------------------|
| Web edge and web center-line guiding    | ✓           | ✓   | ✓                                   |
| Electronic remote adjustment            | ✗           | ● Additional commander                                    | ● Additional commander/<br>fieldbus |
| Removable keyboard                      | ✗           | ✓   | ✓                                   |
| Remote control via I/O                  | ✓           | ✓   | ✓                                   |
| Error output / OK relay                 | ✓           | ✓   | ✓                                   |
| Additional locking in automatic mode    | ✗           | ✓   | ✓                                   |
| Networking via fieldbus module          | ✗           | ✓ CAN open<br>● Ethernet UDP via<br>additional C2E module | Various fieldbus systems*           |
| Motor-driven sensor adjustment          | ✗           | ✓   | ✓                                   |
| Oscillation                             | ✗           | ✓   | ✓                                   |
| Web width measurement                   | ✗           | ✓   | ✓                                   |
| Watchdog via additional web edge sensor | ✓           | ✓   | ✓                                   |
| Master/slave guiding                    | ✗           | ✓   | ✓                                   |
| External locking input                  | ✓           | ✓   | ✓                                   |
| Position guidance in manual mode        | ✗           | ✓   | ✓                                   |
| External analog input for machine speed | ✗           | ✓   | ✓                                   |
| BST.Help / Access via QR code           | ✗           | ✓   | ✓                                   |
| Object guiding                          | ✗           | ✓   | ✓                                   |
| Line and contrast guiding               | ✓           | ✓   | ✓                                   |

\*CAN open, Profinet, Profibus DP, Ethernet UDP, Ether CAT, Powerlink

# Additional operating unit

The individual requirements of your machine or production processes mean it may be necessary to run web guiding at several points. The modular design of the ekr CON 600 and ekr CON 600 net devices allows easy installation of an additional operating unit anywhere on the machine.

## Various fieldbus modules

The ekr CON 600 net can be easily integrated into your machine control with various fieldbus modules. In doing so, the web guiding can be remotely controlled or different parameters can be queried to improve your overall process. As always, our focus here is on the simple and transparent design of the fieldbus connection.

The ekr CON 600 net is constantly being redeveloped with regard to the various fieldbuses. The following fieldbuses are currently available: CAN, Profibus DP, Profinet, Powerlink, Ethercat, or Ethernet UDP



*ekr commander*



*ekr 500 digital Unit Touch  
ekr CON 600  
ekr CON 600 net*



BST Sensors

# Perfect Sensors for Your Quality Assurance

## The Optimal Scanning System for Every Material

Our sensors can be connected to a wide range of BST components to guarantee optimum adaptation to your task at hand. The numerous BST solutions also make use of a wide range of sensors to handle web guiding tasks, including ultrasonic and optical models. What's more, they are

also suitable for web edge guiding and web center-line guiding, as well as object and contrast guiding methods.



### Ultrasonic Sensors (US)

Ultrasonic waves are used for contactless scanning of the web edge.

#### Properties of the Ultrasonic Sensors:

- » Resistant to dirt and variations in material transparency
- » Measurement data not impacted by variations in height of material in the sensor measurement area
- » Compensation for interference from external sources of noise and other environmental influences
- » Large proportional measurement areas (\*US SEN 3xx) allow for guiding without mechanical adjustment of the sensors, even if there are relatively large variations in the web width
- » Same mechanics as IR sensors, allowing for simple communication between US and IR in both directions

#### Applications:

- » Materials with dust- or fiber-like deposits
- » Foils and films with variations in transparency
- » Light-sensitive materials

### Optical Sensors (IR)

Light is used for contactless scanning of the web edge.

#### Properties of the Optical Sensors:

- » Optical scanning (impervious to external light)
- » Measurement data not impacted by variations in height of web in the measuring light beam
- » Optional connection for cleaning air protects the optics from contamination caused by lint or abrasion particles (IR 2011)
- » Large proportional measurement areas allow for guiding without mechanical adjustment of the sensors, even if there are relatively large variations in the web width (\*IR SEN 4xx)
- » Same mechanics as US sensors, allowing for simple communication between US and IR in both directions

#### Applications:

- » Transparent and non-transparent materials
- » Thick materials

### Camera Sensors

The web is scanned by recording patterns or contrasts on the web.

#### Properties of the Camera-based Sensors:

- » Optical scanning with CCD lines or area scan cameras
- » Automatic exposure adjustment to different ambient conditions
- » Integrated or additional lighting options

#### Applications:

- » High-precision scanning of opaque materials in reflected or transmitted light processes

„No web guiding without reliable high-precision sensors for detecting the web edge or objects on the web. Whether acoustic, optical or camera-based - the BST sensors are highly accurate, insensitive to interference and safe. Thanks to plug-and-play connection technology, conversion or retrofitting is also very easy.“

*Ingo Ellerbrock, Head of Product Management*



# CLS CAM 100 State-of-the-Art Guiding

## Sustainable and Highly Flexible Processes Through Object Guiding

A stable and precisely guided web forms the basis for all web forming processes. But with sustainability becoming an increasingly important consideration, there is so much more to consider now than simply quality. What if we could offer you a solution that allowed you to save on material without compromising on maximum precision and efficiency? A solution that places you as the user right at the center while also setting new standards in intuitive user guidance and flexibility. Introducing the camera-based **CLS CAM 100** sensor for web guiding on an object-specific basis.

- » Precise scanning of objects, lines, print edges, or web edges with a color matrix camera
- » Guiding on an object-specific basis offers the following advantages over conventional guiding criteria:
  - An additional guiding line is no longer necessary, saving on material and costs.

- Potential fluctuations in the web tension no longer have any influence on the guiding accuracy, since the CLS CAM 100 also offers the possibility to scan for objects directly in the center of the web.
- » Extreme reliability at web speeds of up to 1,200 m/min
- » Optimal lighting conditions thanks to automatically guided LED lighting integrated into the sensor head
- » Intuitive user guidance along with quick and easy operation:
  - The guiding criterion is selected by swiping the 7" touchscreen display.
  - Guiding criteria can be easily saved for even faster pattern changes
- » Straightforward commissioning
  - No need to set up an additional trigger or trigger signal
  - Installation on current BST controllers via plug and play
- » Large measuring range of 60 x 40 mm for guiding criteria up to 30 x 30 mm and precise web guiding results

## CLS CAM 100 – Your Benefits at a Glance:

When it came to developing the CLS CAM 100, BST was as committed to focusing on the needs of the operator as much as the technology itself:

- » The intuitive 7" touchscreen display of the CLS CAM 100 allows users to set relevant guiding criteria by means of gesture control while also serving as an observation monitor.
- » The CLS CAM 100 can be installed in new machines as well as retrofitted to existing production systems.



CLS CAM 100 sensor system

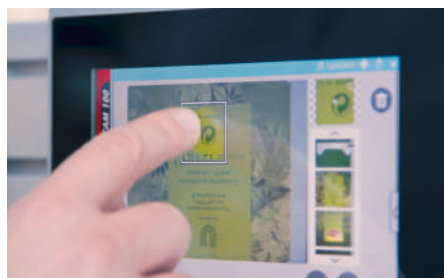

Intuitive selection of guiding criteria by swiping the 7" touchscreen display



CLS CAM 100 in use

# CLS Pro 600

## Perfect line and contrast guiding

Do you need a sensor that offers high-precision, pinpoint guiding based on print lines, print edges, or web edges? Should this sensor be easy to operate, provide clear feedback about the measuring status, and function reliably, even on critical materials such as reflective surfaces?

Then the CLS Pro 600 digital sensor is just what you need.

The high-performance, user-oriented functions of the CLS Pro 600 allow you to produce the highest quality for your customers:

- » Precise scanning of lines, print edges, or web edges with color sensors
- » Optimal lighting conditions thanks to automatically guided LED lighting
- » Extreme reliability, even at the highest web speeds
  - The high scan rate of 500 Hz enables precise guidance at high web speeds – even with interrupted lines or contrasts
- » Clear and intuitive integrated color display
- » Convenient selection of the print line, print edge, or web edge thanks to color display of contrasts
  - Laser projection onto the center of the measurement range allows easy alignment and adjustment of the camera

- » Intuitive user guidance and easy operation
  - Clear operating panel
  - Automatic positioning of the CLS Pro 600 in conjunction with the FVG POS 100 sensor positioner to minimize setup time
- » Removable operating unit for installation in a central position in the machine
- » Additional standardized output signal of 0–10 volts in combination with a lock signal
- » USB interface for parameter and job storage

### Perfect Technology

When it came to developing the CLS Pro 600, BST was as committed to focusing on the needs of the operator as much as the technology itself:

- » All messages and values are clearly shown on the color display and easy to read at any time.
- » The versatile menu interface is designed to allow the operator to individually define their own essential functions and launch these at the touch of a button.
- » Different levels of user authorization secure production and protect the safety-relevant parameters against unauthorized access.
- » The CLS Pro 600 is very easy to operate thanks to the intuitive user guidance and clear menus.

- » The system is controlled via a control panel that can be swiveled up to 180° on a guide ring.
- » The operating unit can be removed and installed in a central position as required – for example, when installing the sensor in hard-to-reach places.
- » Parameter lists and job data can be copied to other CLS Pro 600 sensors using the USB interface.
- » The mounting fixture assists with correct alignment of the sensor in the machine.
- » Job/slot memory for simplified commissioning





# CCD CAM 100

## Reliable, High-Precision Web Guiding

The high-performance CCD CAM 100 sensor is able to detect and measure up to eight web edges. The resolution of up to 60,000 pixels ensures the utmost precision. The integrated high-resolution display enables quick, effective alignment of the sensor. The production and setup parameters are quickly and securely transferred via the integrated network interface.

The CCD CAM 100 features an SD card slot for saving the setting parameters and making these available to other cameras as required. This allows you to cut down on machine downtime significantly, since the camera can be

replaced and set up again in just a few minutes.

What's more, integrated LEDs project points of light into the camera's field of vision, making it easier to align and position the sensor. Positioning takes place directly on the camera by means of a guided process.

An optional fine adjustment feature has been specially developed for this camera to facilitate its mechanical alignment significantly.

A color touchscreen display integrated into the camera simplifies communication with the machine operator

and provides the relevant information on operating parameters, the video curve, and even fault diagnostics at any time.

**Technical Data (Extract):**

- » RGB color chip with 3 x 10,000 pixels
- » Scan rate up to 10 kHz
- » Connectivity via the BST CAN bus
- » Encoder input and 4 universal outputs – e.g., for controlling the lighting unit



US 2010



IR 2011



US SEN 3xx &  
IR SEN 4xx



CLS CAM 100



CLS Pro 600



CCD CAM 100

|                    | Form                      | Measurement range [mm]                                       | Resolution        | Measuring distance [mm] | Output signal (analog) | Output signal (digital) |
|--------------------|---------------------------|--|-------------------|-------------------------|------------------------|-------------------------|
| <b>US 2010</b>     | Prong width 40 mm, 70 mm  | 12   | Typically 0.05 mm | -                       | 0-10 V                 | BST CAN bus             |
| <b>IR 2011</b>     | Prong width 40 mm, 70 mm  | analog: 16 mm<br>digital: 24 (IR 2011/40)<br>20 (IR 2011/70) | Typically 0.05 mm | -                       | 0-10 V                 | BST CAN bus             |
| <b>US SEN 3xx</b>  | Prong width 38 mm, 101 mm | 30-467   | Typically 0.05 mm | -                       | -                      | BST CAN bus             |
| <b>IR SEN 4xx</b>  | Prong width 38 mm, 101 mm | 30-284   | Typically 0.05 mm | -                       | -                      | BST CAN bus             |
| <b>CLS Cam 100</b> | Camera                    | 60 x 40  | 640 x 480 px      | 25-40                   | -                      | BST CAN bus             |
| <b>CLS Pro 600</b> | Camera                    | 25   | 0.005 mm          | 25                      | 0-10 V                 | BST CAN bus             |
| <b>CCD CAM 100</b> | Camera                    | Variable   | 1/60,000 px       | 300-900                 | -                      | BST CAN bus             |



| Edges                   | Measuring medium / lighting         | Protection class | Special functions   | Compatible with controllers              |                 |             |
|-------------------------|-------------------------------------|------------------|---|--|-----------------|-------------|
|                         |                                     |                  |   | ekr 500 Digital Unit Touch / ekr CON 600 | ekr CON 600 net | ekr CON 100 |
| 1                       | Ultrasonic                          | IP 54            |   | ✓  | ✓               | ✓           |
| 1                       | LED, red                            | IP 54            |   | ✓  | ✓               | ✓           |
| 2                       | Ultrasonic                          | IP 40            | Dynamic compensation  | ✓  | ✓               | ✓           |
| 2                       | Infrared                            | IP 40            | Dynamic compensation  | ✓  | ✓               | ✓           |
| 2 ; pattern recognition | Optical/LED, white                  | IP 54            | Object guiding without trigger; multi-touch color display                     | ✓  | ✓               | ✗           |
| 2                       | Optical/LED, white                  | IP 54            | Touchscreen color display, line/contrast recognition (including broken lines) | ✓  | ✓               | ✓           |
| 8                       | Optical/LED, white (not integrated) | IP 54            | Color display, integrated alignment and positioning assistance                | ✓  | ✓               | ✗           |

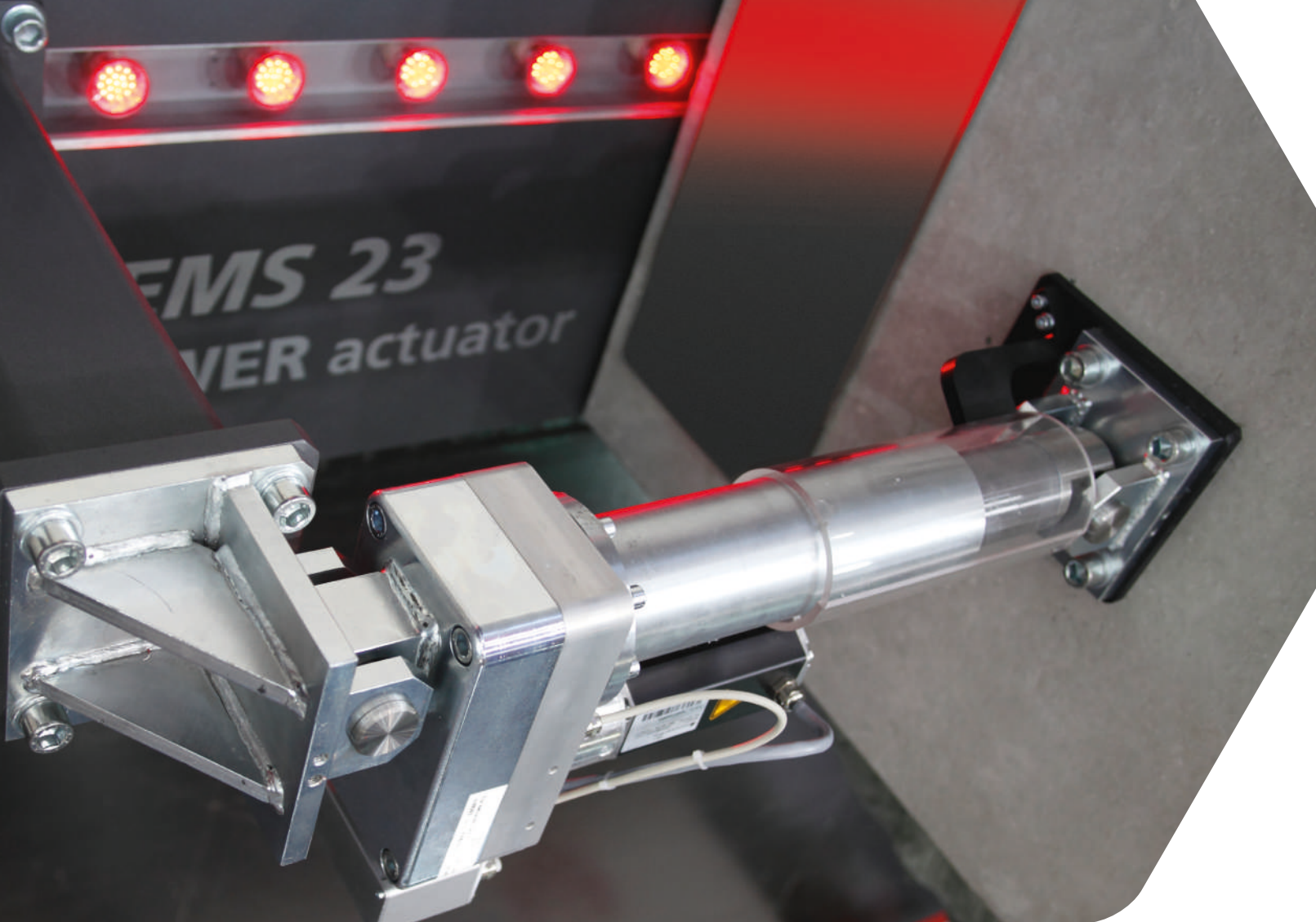

## BST Actuators

# High-Performance Position Guiding for Every Need

### Electric Motor-Driven Actuators

Electric motor-driven actuators are used wherever extremely quick reactions to changes in web position are required. The actuators can be connected directly to the controller. The ready-to-connect design enables quick, low-cost installation, which is also advantageous in the retrofitting of existing systems.

### Performance data

BST actuators can be used in conjunction with our actuators to handle a variety of web guiding tasks. We offer electric motor-driven actuators with

positioning forces of up to 10,000 N and strokes of up to 295 mm in versions with position feedback.

### Properties of the electric motor-driven BST actuators:

- » Low-wear motors
- » Ball screw spindle actuators for long service life and minimal play
- » Designed for curved and linear correcting movements
- » Different combinations of stroke, positioning force, and positioning speed available
- » Integrated position feedback (precise detection of the current actu-

ator position) as well as electronic end position switch-off

- » BST actuators are maintenance free

**Please do not hesitate to contact us for advice on higher actuating forces/speeds – our experts will be happy to help.**

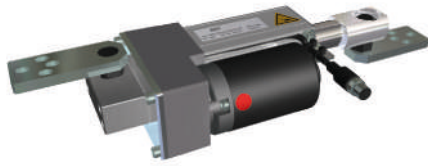

**EMS 18 actuator**  
Up to 200 mm stroke at max. 840 N

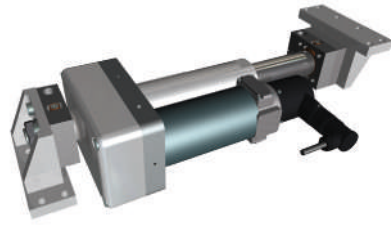

**EMS 21 actuator**  
Up to 195 mm stroke at max. 1,680 N

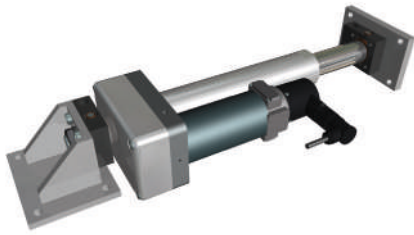

**EMS 22 actuator**  
Up to 195 mm stroke at max. 2,250 N

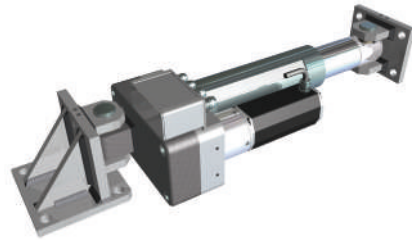

**EMS 23 actuator**  
Up to 295 mm stroke at max. 10,000 N

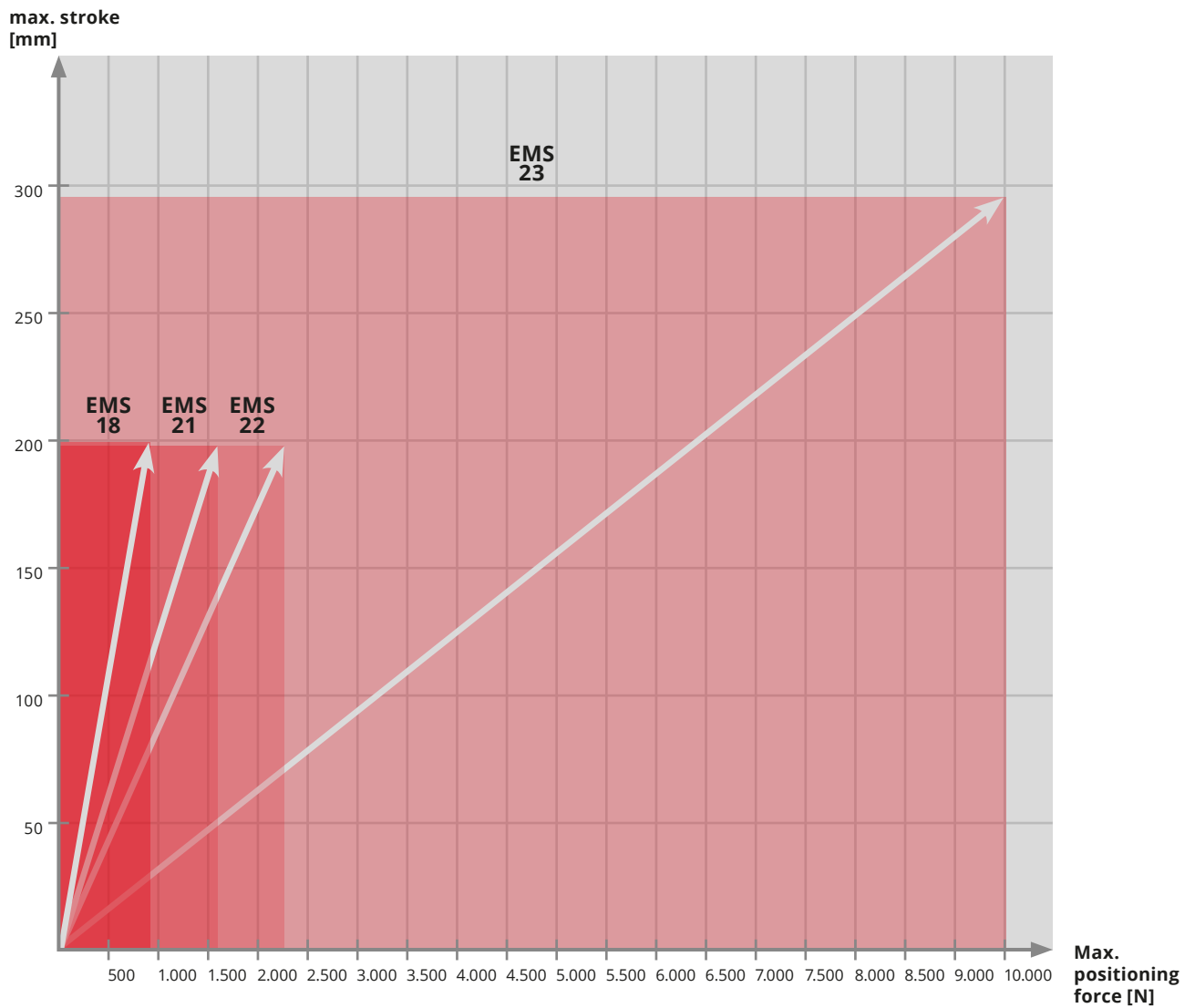



# Electric Motor-Driven Sensor Positioning

If the location of the sensor is difficult to access, or if the scanning position has to be changed frequently to accommodate varying web widths, a sensor positioner (FVG) handles the adjustment of the sensor position. A range of different automatic systems with electric motor-driven actuators are available to meet your individual needs.

## Sensor Positioner FVG POS 100

The sensor positioner FVG POS 100 is ideal for a range of different applications and is available in a number of variants. Functions such as edge guiding and web center guiding (even with

a variable web center) are standard. Intelligent communication with the controller is achieved via plug & play, meaning that setup and initial start-up are largely automated. The modular design of this sensor positioner allows it to be used for large web widths, as well.

BST FVG POS 100 devices are simply connected to the controller like a sensor to quite literally extend the measuring range of the sensor. Parameterization or configuration is not necessary.

|             | Guiding               | Function   | Special functions   | Required controller                        |
|-------------|-----------------------|--|---|--|
| FVG POS 100 | Web edge              | Automatic edge search  | • Oscillation   | ekr CON 600 and ekr 500 Digital Unit Touch |
| FVG POS 100 | Web edge / web center | Automatic edge search and guiding to edge 1, edge 2, web center (independent of one another) | • Web width measurement<br>• Offsetting of the center for off-center (narrow) webs<br>• Oscillation | ekr CON 600 and ekr 500 Digital Unit Touch |



Sensor positioner FVG POS 100



BST Web Guiding

# SMARTData

## Efficient Production. Digital Communication.

**SMARTData allows you to view complex production processes in their entirety. What's more, the central data management complete with open interfaces makes it possible to integrate various different systems – including systems and sensors from other suppliers.**

This is exactly how SMARTData supports comprehensive quality documentation and analyses, making it easier for users to operate, guide, analyze, optimize, and document production processes from a central position.

BST offers a wide variety of compatible web guiding components,

ensuring that any system can be perfectly adapted to your individual needs. All controllers have several ports: Some are for various sensors, guiding devices, and actuators of different power levels, and others are for connecting the controllers to your machine control system.

BST web guiding systems provide you with information that you can integrate directly into your production processes. By the same token, you can also operate the BST system from your control center.

It records time-sensitive process data from real-time operations, ensuring that you are always precisely

informed of the latest data from your entire system. With simple internal and external networking, convenient operation, extreme interference protection, fast and secure signal transmission, and minimal wiring thanks to a handy plug-and-play system, BST makes a valuable contribution to your quality assurance with our fieldbus system.

BST also allows you to choose between a number of different gateways to connect BST web guiding systems to all conventional bus systems (such as CAN bus, Profibus DP, ProfiNet, and Ethernet).



# SMARTData



BST GmbH  
Remusweg 1  
33729 Bielefeld  
Germany

T +49 521 400 70-0  
[www.bst.elexis.group](http://www.bst.elexis.group)  
[info@bst.group](mailto:info@bst.group)